

Encouraging Student Participation in Developing Custom Built Lab Modules in Undergraduate Engineering and Science Course

Dr. Anu Osta, Rowan University

Dr Anu Osta is a Senior Lecturer in Mechanical Engineering Department at Rowan University. His teaching interests are Engineering Mechanics, Materials Science, Manufacturing, and Design.

Encouraging student participation in developing custom built lab modules in undergraduate engineering and science courses

1. Introduction

Higher education has for quite some time witnessed a surge of promising strategies that enhance student engagement and learning, such as flipped classrooms, online courses, field activities, hybrid or blended learning approaches, hands-on project based activities and more. These have proven effective tools in capturing students' attention and facilitating their learning. These learning strategies are part of the pedagogical technique known as active learning. They help solidify abstract concepts and understand theoretical principles by engaging the students in active learning. Building, testing, and observing real-world systems ignite critical thinking, better information retention, troubleshooting, and improved technical competency among the students. Building educational tools or demonstration devices offer several advantages that can significantly enhance student understanding of concepts compared to traditional, passive learning methods like lectures and textbooks. Tools and devices allow students to experiment with variables, test hypotheses, and observe outcomes directly. Most of us learn best visually or kinesthetically, for example building a simple bridge model and demonstrating the loading on that device would help us understand the principles of forces, weight distribution, and structural stability. When students use the experimental module collaboratively then the activity promotes teamwork and peer to peer communication, inviting diverse perspectives on the subject thus enriching the learning experience.

2. Literature review

Active learning emerged in the early 1960s^{1,2} as a popular strategy, demonstrating its effectiveness in engaging students with the learning process. Initially introduced within a reform pedagogy known as 'guided inquiry'³, active learning unfolds in three phases: exploration, invention, and application. Research suggests that this pedagogical approach substantially enhances students' conceptual understanding when compared to traditional teaching methods^{4,5,6}.

Encouraging engineering faculty to incorporate active learning strategies, in classroom instruction is common. There is a necessity to explore self-efficacy at various academic levels to understand variations among different populations. At the same time, further research is required to assess the nature and scope of impact of active learning on the learning successes of students in engineering and science courses. ABET's Criterion 3, Outcome 6, emphasizes the development of critical thinking skills in graduates. This outcome requires them to design and conduct experiments, analyze and interpret data, and apply engineering judgment to reach well-supported conclusions. While many engineering students demonstrate strong understanding of engineering systems and the ability to approach problem-solving however most of them fail to harness their ideas into a functional (practical) design. For this reason lab or project activities are often attached or integrated into engineering courses. Classroom lectures tend to focus more on the concepts together with a pen and paper approach towards problem solving. Yet, the practical application of these principles and concepts undergoes testing during the design thinking aspect of project or laboratory components within the courses. In addition to this many traditional university programs need to evolve their teaching methods to equip students with the innovative, creative, and integrated engineering-business skillsets that thrive in today's technology-driven global economy. The entrepreneurial skillset is highly desirable by the companies today especially those employed in R&D^{7,8,9}. Most of the labs which are integrated into the engineering courses have some common themes as their objectives

- engage students in activities related to experimentation including data acquisition, data analysis, data interpretation
- engage students in activities related to design and simulation tools
- engage students in communicating their results to their community via reports, presentations, etc
- cultivating the technical and academic maturity students need to thrive in the industry or in academia.

In several accredited universities, the Senior Design Capstone is a required component of the undergraduate engineering programs. Capstones are culminating experiences offered in senior year or towards the end of an engineering program and are designed to promote application and synthesis of the knowledge and skills acquired throughout the undergraduate engineering education to solve real-world engineering problems. These courses often involve complex

projects requiring teamwork, communication, problem-solving, critical thinking, and time management. Students also learn to present their work effectively and defend their solutions in a professional setting. Capstone courses are project-based and faculty guided and will often require a multidisciplinary approach to problem-solving and team collaboration to leverage each other's strengths. Project management skills, critical thinking and team collaboration are key characteristics of the capstone.

A large volume of literature exists that describes lab and project activities in engineering and science courses and how it helped in learning successes. It will not be possible to mention all of them here, so only a few relevant studies are being mentioned. Hennessey¹⁰ describes 4 different hands-on lab projects used in an abbreviated lab of a combined statics and dynamics course. They were 3D static equilibrium demonstrator and 2D truss analysis and fabrication for statics, vehicle wheel mass moment of inertia demonstrator and pendulum style golf putter for dynamics. Other similar studies cited are [11-17]. However implementing project-based learning comes with its own challenges¹⁸ due to extended project durations, the difficulty of balancing student autonomy with class control, and the need to integrate this approach into a system reliant on formal evaluations and exams. Ideally, students should begin working on their capstone projects in their junior academic year but current implementation often places them in the final semester, limiting meaningful topic selection that would comprehensively assess students' learning outcomes. Davishahl¹⁹ outlines recommendations for supplemental activities by suggesting to integrate these activities with the course content such as lectures and assignments, providing video tutorials demonstrating 'how to problem-solving', building interactive feedback to prevent students from working on incorrect solutions, and leveraging peer support.

This paper will focus on development of certain experimental hands on tools that would serve as short lab components or as demonstration modules in order for students to understand the concept better or visualize its practical application. The first is a torque or torsion demonstrator, the second is a work and energy principle demonstrator and the inclined plane friction demonstrator.

3. Discussion

At Rowan university an eight semester sequence of courses is conducted known as Engineering Clinics. It emphasizes a hands-on approach to learning, is integrated with supporting course work, creates a multidisciplinary community consisting of students working in teams, and

reinforces a value based engineering by encouraging entrepreneurial mindset. The course is required for all engineering majors. Students and faculty from all six engineering departments work side-by-side on laboratory experiments, design projects and research that stem from real-world scenarios. Junior and Senior Clinics are managed by each of the individual departments. Students choose their top choices from a bank of well over 100 projects at the start of each semester and then complete the research or design according to the stakeholder's specifications. The projects discussed here were accomplished as a part of the clinic courses.

3.1 Torque/Torsion Demonstrator

This activity introduces a teaching tool to explore torque and its relationship with force. Understanding torque is crucial in courses like statics, dynamics, materials science, and machine design, all of which students encounter early in their studies. In a material science and manufacturing course for second-year students, the topic of torsion is covered in the chapter on mechanical properties. This chapter explores concepts like shear stress, shear strain, rigidity modulus, and the mechanical response of materials under torsional loading. To enhance understanding, a 3D-printed model of a torsion tester was made (Figure. 1). This model showcased the sample grips, drive motor assembly, and data acquisition unit. The 3D model was passed around during the class for the students to touch and feel.

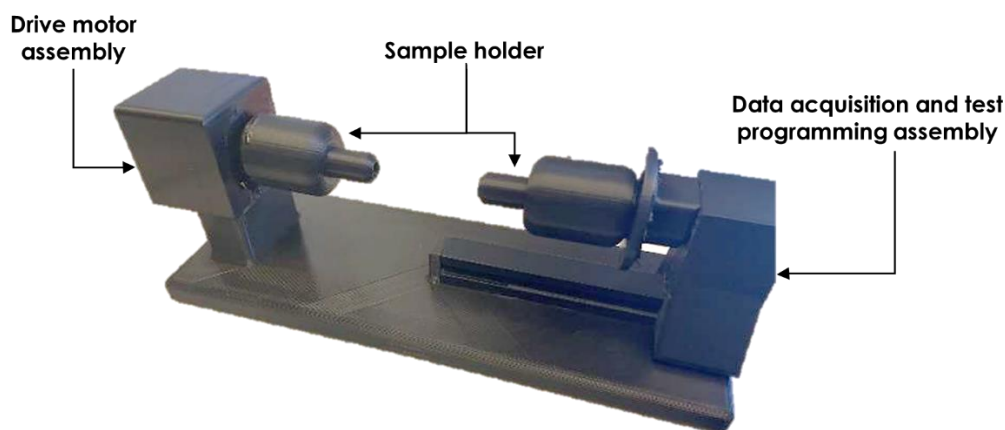

Fig. 1. 3D printed mock-up of a torsion tester

In addition to this another device, the torque demonstrator was also developed. The sketch is shown in the Figure 2 below.

Device Description

The device basically consists of a rod that serves as the torque shaft which had a 3D printed handle on one of its ends. This shaft is supported on two roller bearings press-fitted onto two supports. There is an aluminum adapter in the middle to which a 10 N load cell is attached. The adapter is held onto the shaft via two screws. At the base of the load cell (loading end) an acrylic stop is screwed to the base. The base and the bearing supports are made of 6061 aluminum $\frac{1}{4}$ inch plates.

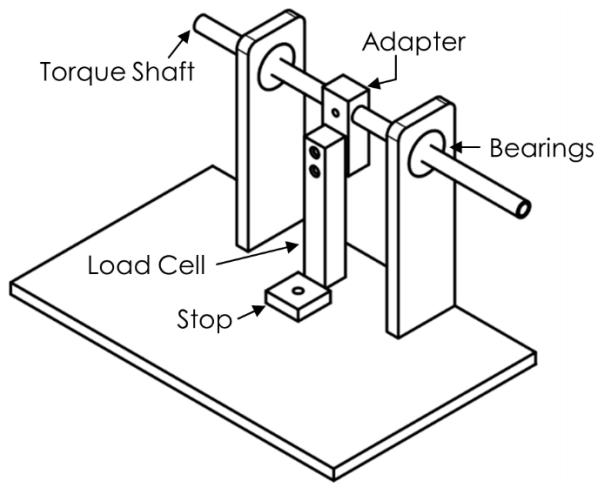

Fig. 2. CAD sketch of the torsion device

The electronics components consists of an Arduino UNO, an HX711 load cell driver, an LCD screen, buttons and wires. The circuit (Figure 3) is the same as a standard weight scale circuit.

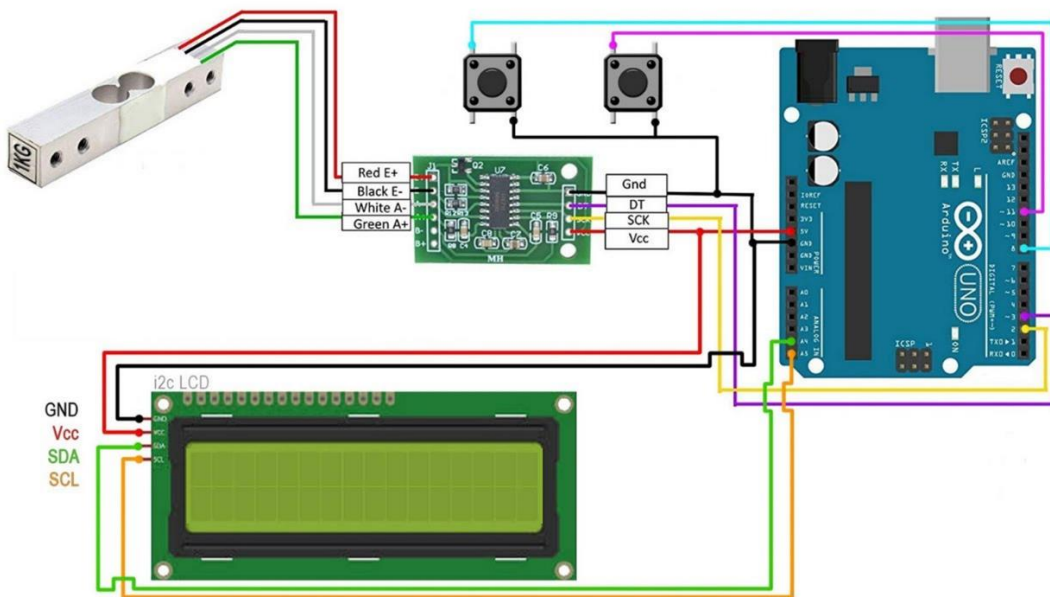

Fig. 3. Circuit diagram of the torsion tester

The electronics were housed in a plywood casing that was laser cut. The front, top and side views of the device are shown in the Figure 4 below.

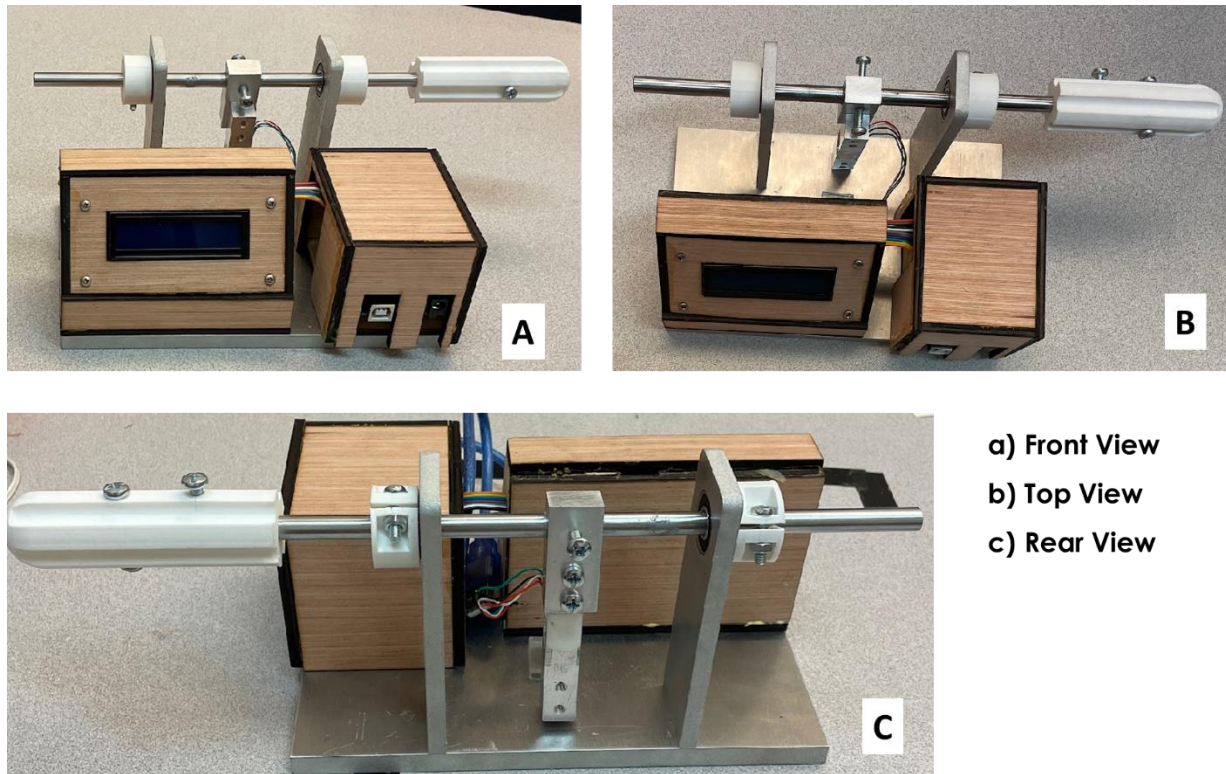

Fig. 4. Front, top and side views of the actual device.

For running the device, a procedure sheet was created. The power chord would plug into a laptop with handle at rest. Once the screen powers on, the handle is spun slowly. Initially the torque reading is zero. When the load cell contacts the stop, the torque value begins to change. As force continues to be applied on the handle the torque value on the screen increases. A snippet of the Arduino code is shown below. The load value in lbs is read from the load cell and stored in the variable `scale.get_units(4)`. This value is then multiplied by the load arm (distance from the shaft center up to the contacting tip of the load cell) length which is 0.4 ft and the value of torque in lb-ft is displayed on the screen.

```
{lcd.begin(16,2);  
lcd.print(scale.get_units(4)*0.4003398);  
lcd.setCursor(0, 1);  
lcd.print("[lb-ft]");  
Serial.println(scale.get_units(4)*0.4003398);
```

The required skills (Figure 5) essential to accomplish this project, include manufacturing skills such as 3D CAD modeling, laser cutting, machining using mill and lathe, measurements, Arduino programming, water jet cutting, 3D printing and basic electrical and electronics engineering. Besides this some degree of project management skills were also required in order to schedule the parts order, machining, programming, etc. A Gantt chart to that effect is also shown in the Figure 6, below.

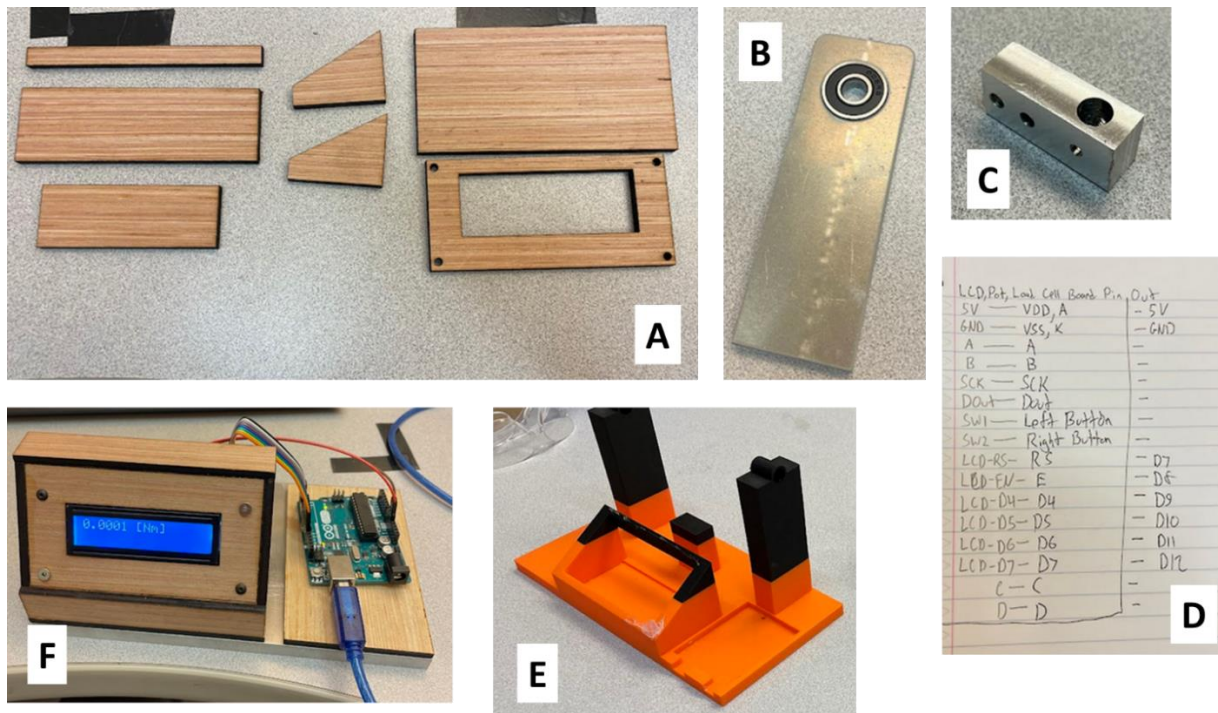

Fig. 5. Skills involved A-Laser cutting, B-Press fitting, C-Machining, D-Basic electronics, E – 3D printing, F- Microcontroller programming and Assembly.

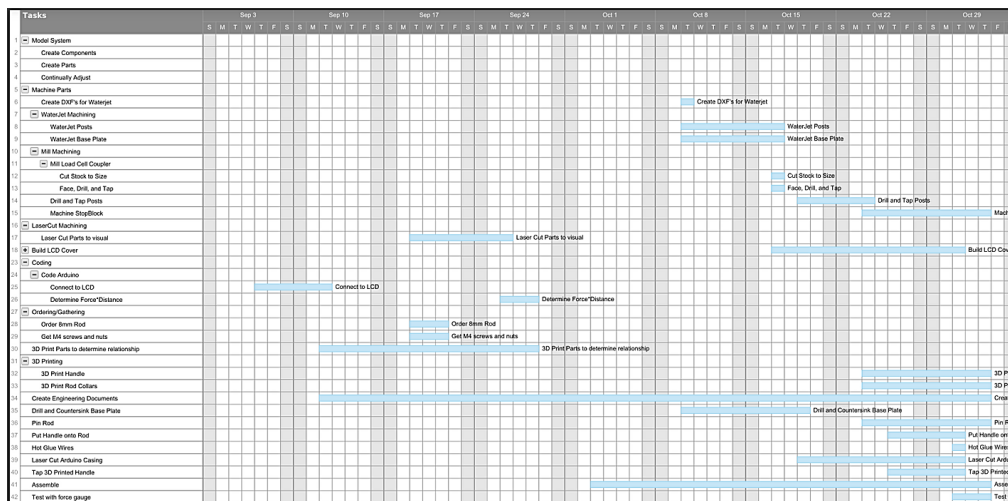
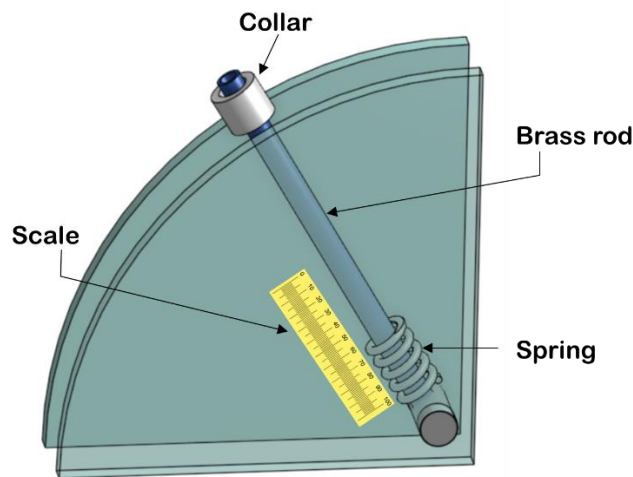

Fig. 6. Gantt Chart

Towards the semester end the students were required to present their projects. Hence one may add presentation skills to the above list. This module can aid in helping students measure torsion stress (or the shear stress), τ resulting from the torque. The shaft is $\frac{1}{4}$ inch in diameter and the torque (T) is being measured. Using, $\tau = \frac{Tr}{J}$ where r is the shaft radius and J is the polar second moment of area, the shear stress is calculated.

3.2 Work-Energy Module

This activity introduces a teaching tool to explore the relationship between work and energy. In the mechanics course, students learn about the work-energy principle, which states that the net work done on an object equals the change in its kinetic energy. To explore this concept in action, a simple apparatus is used. It consists of a smooth brass rod fixed at one end, allowing rotation through various angles. Finally the collar which could be either steel or aluminum is slid on the rod and then let go. The CAD model is shown below in Figure 7.



3/106 The 2-kg collar is released from rest at A and slides down the inclined fixed rod in the vertical plane. The coefficient of kinetic friction is 0.40. Calculate (a) the velocity v of the collar as it strikes the spring and (b) the maximum deflection x of the spring.

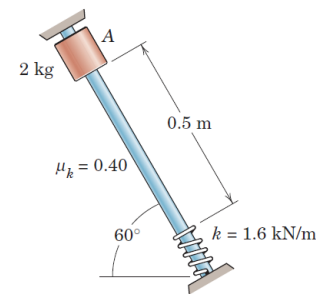

Problem 3/106

Fig. 7. CAD model of the Work-energy device (*left*) and the text book problem (*right*)

This apparatus was modeled on a textbook problem chapter 3, number 106, Engineering Mechanics Dynamics, Volume 2, Eighth edition by J.L. Meriam and L.G. Kraige.

The problem statement is given below:

The 2-kg collar is released from rest at A and slides down the inclined fixed rod in the vertical plane. The coefficient of kinetic friction is 0.40. Calculate (a) the velocity v of the collar as it strikes the spring and (b) the maximum deflection x of the spring.

During the class demonstration the students would be asked to first measure the weight, w of the collar on a scale and find its mass, $m = w/g$ where $g =$ acceleration due to gravity. They would then calculate the total potential energy of the collar before it is released (Figure 8).

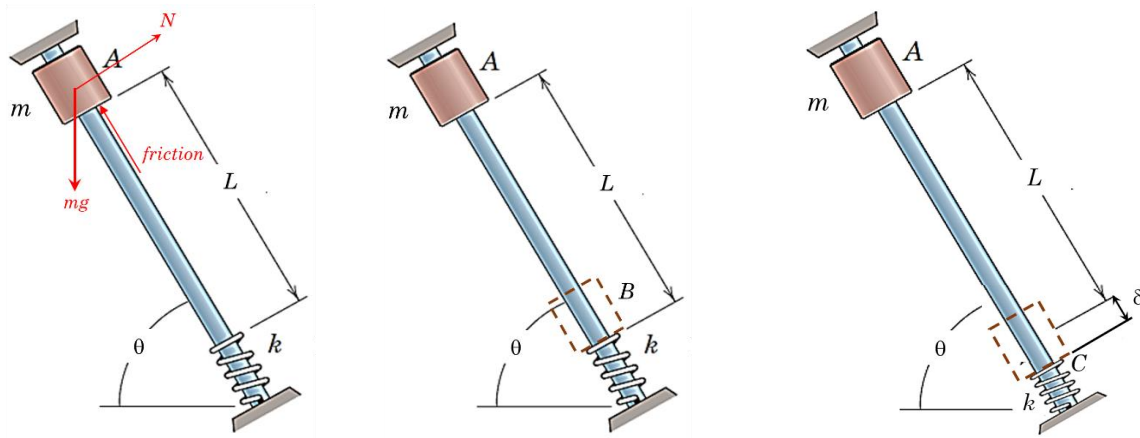

Fig. 8. The three stages of energy conversion A, B and C.

The work done would be calculated by multiplying the (weight – friction) component along the rod’s direction with the length of the rod. This would be equal to the kinetic energy of the collar ($\frac{1}{2}mv^2$) when it arrives at B, before impacting the spring. The kinetic energy before spring compression would then be converted to the elastic potential energy of the spring at B after compression ($\frac{1}{2}k\delta^2$). The spring compression is obtained by recording a video of the impact process and observing the spring deflection against a circular scale in the background as shown in the Figure 9, below.



Fig. 9. A student video recording the collar-spring impact

The still-image grabs from a video of the impact sequence is shown in Figure 10, below.

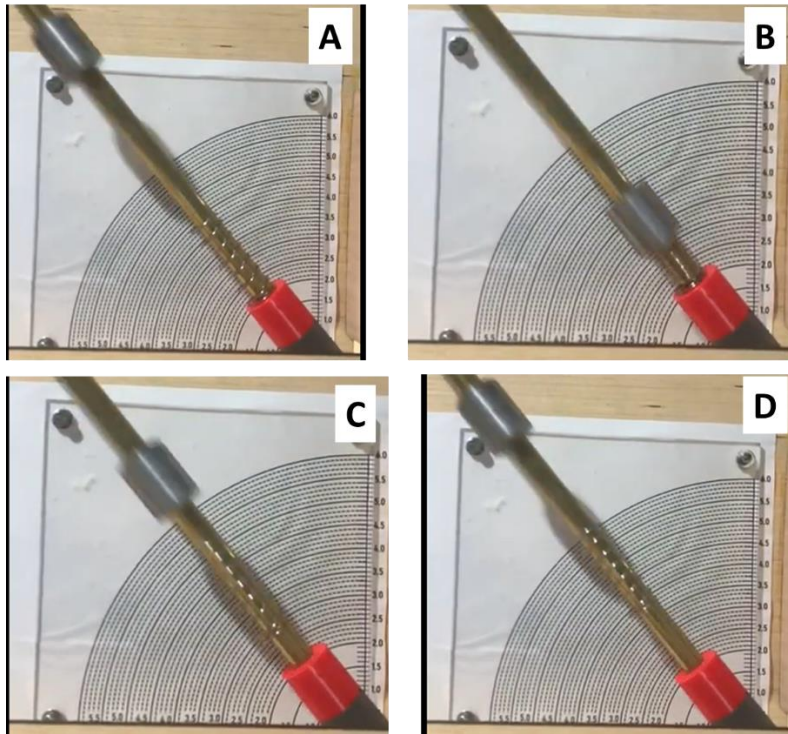

Fig. 10. A close-up of the spring deflection during its impact with the collar

This apparatus also was developed as a part of the clinic project. The required skills essential to accomplish this project, include manufacturing skills such as 3D CAD modeling, laser cutting, machining using lathe for turning the collar, measurements, and 3D printing. Besides this some degree of project management skills were also required in order to schedule the parts order, machining, programming, etc.

3.3 Inclined plane friction Module

This activity introduces a teaching tool to study the “block on the inclined plane” case a topic frequently covered in both statics and dynamics. Within the Statics course, the module delves into the notion of static friction (the force that keeps object from slipping,), while in dynamics, it explores the Newton’s second law $force (F) = mass (m) * acceleration (a)$ which tells us how forces affect motion. The forces are decomposed uphill and downhill components and then the equilibrium equations are satisfied. The Figure 11 shows the free body diagram of the problem setup and the CAD model.

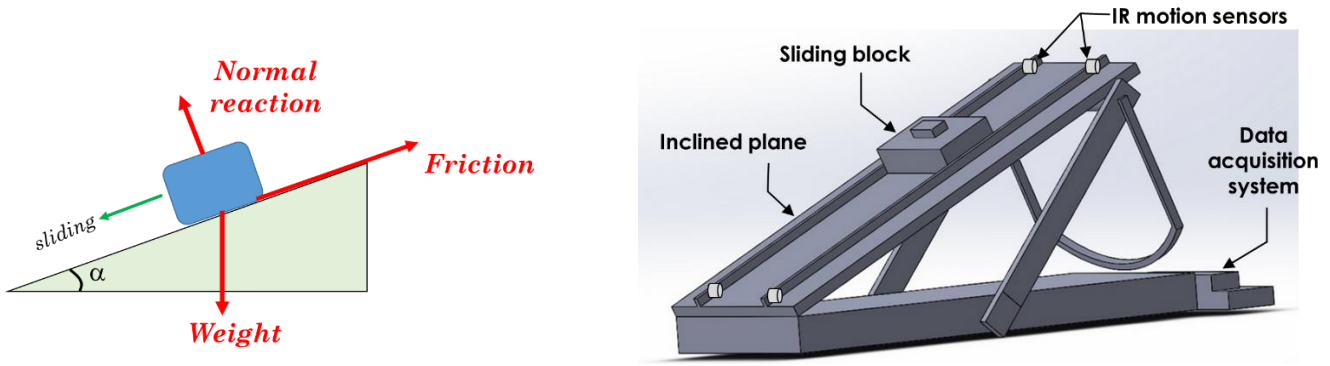

Fig. 11. Free body diagram of the case setup (left) CAD model of the apparatus (right)

The apparatus is made of MDF board and plywood and has support member to lock it in place at a particular angle. Another wooden piece housing an MPU6050 6-axis Accelerometer Gyroscope Sensor serves as the sliding block. There is an electronics control unit attached to the device that contains an Arduino nano, an LCD screen, a PCB board and a switch (Figure 12).

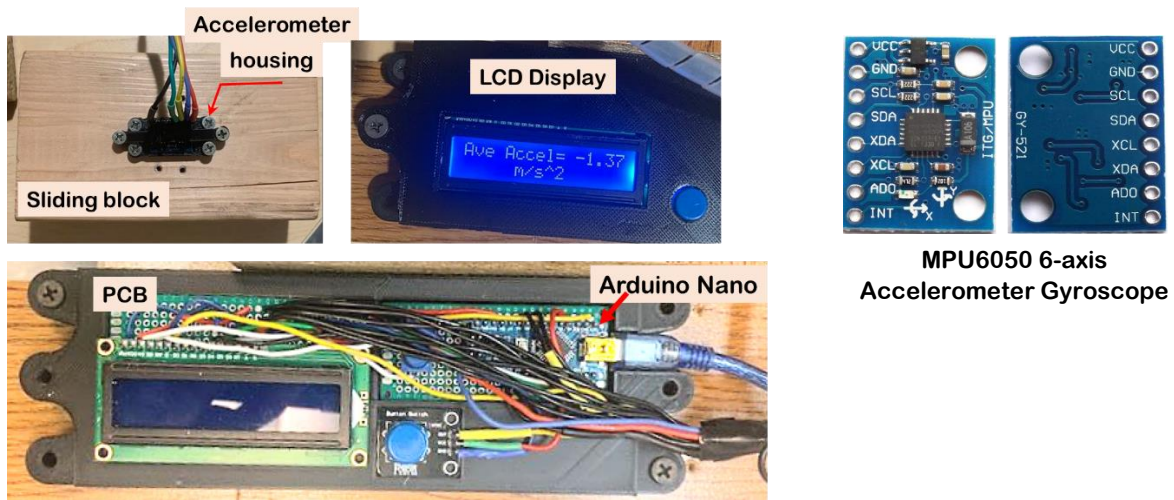

Fig. 12. The electronics unit and its components

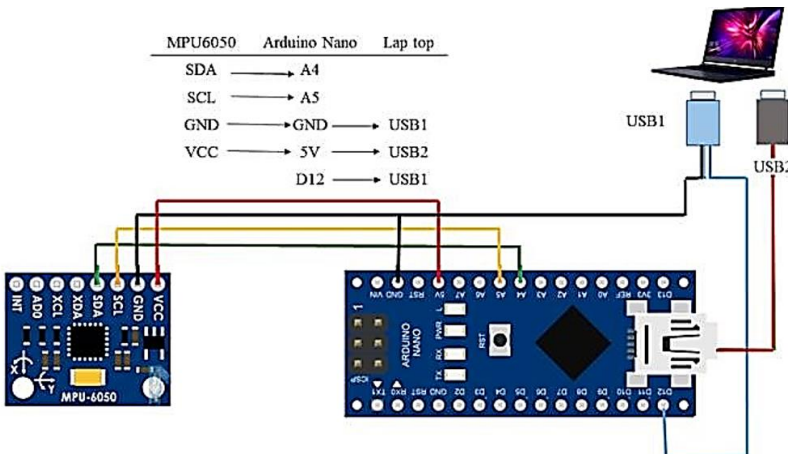

Fig. 13. The circuit diagram²⁰



Before sliding commences



During the sliding of the block

Fig. 14. The experiment begins with the block positioned at the ramp's highest point. A loose wire connects it to the accelerometer (*left*). Once released, the block slides down the ramp, passing two sets of optical sensors positioned along its path (*right*).

The circuit diagram was adopted from Zolfaghari²⁰ (Figure 13). Figure 14, illustrates the steps involved in a single experimental run. First, the Arduino is powered up. Then, the block with the accelerometer attached to it is positioned at the ramp's highest point, with a loose wire tether. Upon pressing the blue switch, the LCD displays the message "Release Block." Once released, the block slides down, passing two sets of optical sensors. The first beam sensor starts a timer, and the accelerometer starts recording acceleration data every 10 milliseconds as the block travels down the ramp. This recording continues until the block disrupts the beam sensor at the ramp's lower end. The accelerometer considers the ramp's direction as the x -axis and calculates the average acceleration experienced during the time it took the block to pass between the two infrared motion sensors. Finally, the screen displays the acceleration in meters per second squared (m/s^2). Additionally, the serial monitor logs all the acceleration readings captured during the block's descent, along with corresponding timestamps.

The development of this apparatus was part of a clinic project. It required various skills, including:

- *Manufacturing skills:* 3D CAD modeling, woodworking, fastening, precise measurements, basic electronics, Arduino programming and 3D printing.
- *Project management skills:* Coordinating parts orders, scheduling woodworking and programming tasks, and ensuring project flow.

4. Conclusion

The purpose of such a project was twofold – (a) to add a hands-on activity to the theoretical class lecture on the topics of friction, work and energy, and torque or torsion. Being able to see the theory in practice helps the students verify their understanding, increase student engagement and motivation. This helps them move beyond rote memorization and develop a deeper, more meaningful understanding of the subject matter.

(b) To fulfill the objectives of the Engineering clinics as defined by Sukumaran²¹. They are

1. Demonstrate an expanded knowledge of the general practices and the profession of engineering through immersion in an engineering project environment of moderate complexity;
2. Demonstrate an ability to work effectively in a multidisciplinary team;
3. Demonstrate acquisition of new technology skills through use or development of appropriate computer hardware, software, and/or instrumentation;
4. Demonstrate understanding of business and entrepreneurial mindset;
5. Demonstrate effective use of project- and personnel-management techniques;
6. Integrate engineering professionalism and ethics in their work;
7. Demonstrate improved communication skills, including written, and presentation.

Although the project's results were not evaluated against specific criteria, several observations and experiences were documented. To assess objective (a), we introduced and explained the modules to the relevant classes. Before and after the modules, students were asked generally about their understanding and confidence in the topic. Before the modules were introduced, a considerable number of students hesitated to express their level of understanding and comfort with the discussed topic and remained silent. However for all three modules, there was a significant increase in student confidence after the introduction of the demonstration modules. Documenting the experiences related to objective (b) some notable comments by the students included in their report is given below and certain themes identified is included in parenthesis.

- *The projects that were worked on in this semester were low-cost, with a focus on visual effect and learning potential rather than high precision and industrial use. Both projects stayed under a cost of \$100 (Cost/Budget management)*

- *The projects did not create much waste. All manufacturing processes were completed with scraps in mind. For example, when water-jetting the posts, it was important to reduce consumed space so that as much aluminum could be reused for further projects. If the project were to be disassembled, the components, assuming they are in working order, could be reused in new applications. (Waste/resources minimization)*
- *It was an enjoyable process that required a bit of ingenuity and persistence as well as a decent time stake. A lot of things were unknown and many processes that were completed were new and very challenging. Things such as the implementation of bearings in a build were completely new and made it more difficult to proceed, but with the help of fellow students and faculty, this task would be easy now. Many things along these lines now seem easy and menial since they have now been done before. This will make it much easier in the future to design for manufacturing and of course, to do the actual manufacturing process. (Critical Thinking)*
- *This approach allowed us to tackle the problem presented uniquely. The type of product would need to have many revisions before being presented to the public. The main goal was to over detail each step in the laboratory guide to allow anyone currently taking the course, regardless of their previous academic background and experience level follow through with the guide without any problems. We had hoped to minimize the number of questions as well as the accidents or malfunctions of equipment during the laboratory periods. By doing this, we make sure that all the work we do works soundly so no one can encounter issues during use. This is a professional responsibility for us in this clinic, and by doing rigorous testing on the machines and designs we can guarantee minimal issues during use for all of Professor X's classes (Reliability and Sustainability)*

Acknowledgement: The author wishes to express his gratitude to students Gloria Villagomez, Richard Kurczeski, Shane Vostenak, and Michael Morgan for their valuable contributions towards this work.

References

1. Bonwell, C. C., & Eison, J. A. (1991). Active learning: Creating excitement in the classroom. Retrieved from <http://files.eric.ed.gov/fulltext/ED336049.pdf> Washington, DC: Association for the Study of Higher Education.
2. Meyers, C., & Jones, T. (1993). Promoting active learning: Strategies for the college classroom. San Francisco, CA: JosseyBass Publishers.
3. Karplus, R. & Their, H.D. (1969). *A new look at elementary school science*. Rand McNally & Company
4. Barman, C. R., Barman, N. S., & Miller, J. A. (1996). Two teaching methods and students' understanding of sound. *School Science and Mathematics*, 96, 63-67.
5. Marek, E. A., Cowan, C. C, & Cavallo, A. M. (1994). Student's misconception about diffusion: How can they be eliminated? *American Biology Teacher*, 56, 74-78.
6. Stephans, J., Dyche, S., & Beiswenger, R. (1988). The effect of two instructional models in bringing about a conceptual change in the understanding of science concepts by prospective elementary teachers. *Science Education*, 72, 185-196.
7. The Wall Street Journal: What Employers Want in New Hires (<https://www.wsj.com/articles/lost-learning-remote-pandemic-workplace-skills-new-employees-51351b33>)
8. Forbes: 5 Skills You Need to Be an Entrepreneur (Even If You're Not Starting a Business) (<https://www.forbes.com/sites/forbesbusinesscouncil/2022/09/09/five-tips-to-help-you-become-a-successful-entrepreneur/>)
9. Harvard Business Review: The 7 Skills You Need to Be a Successful Intrapreneur (<https://hbr.org/2018/06/the-myth-of-the-intrapreneur>)
10. Hennessey, M. (2008, June), Statics And Dynamics Projects Emphasizing Introductory Design And Manufacturing Paper presented at 2008 Annual Conference & Exposition, Pittsburgh, Pennsylvania. 10.18260/1-2—3368
11. Ferri, A. A., & Ferri, B. H. (2016, June), Blended Learning in a Rigid-Body Dynamics Course Using On-Line Lectures and Hands-On Experiments Paper presented at 2016 ASEE Annual Conference & Exposition, New Orleans, Louisiana. 10.18260/p.26387
12. Osta, A., & Kadlowec, J. (2016, June), Hands-on Project Strategy for Effective Learning and Team Performance in an Accelerated Engineering Dynamics Course Paper presented at 2016 ASEE Annual Conference & Exposition, New Orleans, Louisiana. 10.18260/p.25444
13. Yother, T. L., & Johnson, M. E., & Thom, J. M. (2018, June), A Course Improvement Strategy That Works: The Improvement of Student Satisfaction Scores in a Lecture and Laboratory Course Using a Structured Course Modification Methodology Paper presented at 2018 ASEE Annual Conference & Exposition , Salt Lake City, Utah. 10.18260/1-2—29671

14. Foust, E. C. (2018, June), Optimizing Students' Learning Experiences in Instrumentation and Measurement Laboratory Paper presented at 2018 ASEE Annual Conference & Exposition , Salt Lake City, Utah. 10.18260/1-2—30850
15. Smith, N. (2020, June), Scaffolded Laboratory Sequence: Mechanics Lab Paper presented at 2020 ASEE Virtual Annual Conference Content Access, Virtual On line . 10.18260/1-2—35173
16. Chang, G., & Peterson, W. (2009, June), Bridge Design Project: A Hands On Approach To Statics And Strength Of Materials Learning Paper presented at 2009 Annual Conference & Exposition, Austin, Texas. 10.18260/1-2—5281
17. Self, B. P., & Widmann, J. M. (2017, June), Demo or Hands-on? A Crossover Study on the Most Effective Implementation Strategy for Inquiry Based Learning Activities Paper presented at 2017 ASEE Annual Conference & Exposition, Columbus, Ohio. 10.18260/1-2—28101
18. R. W. Marx, P. C. Blumenfeld, J. S. Krajcik and E. Soloway, "Enacting Project-Based Science," *The Elementary School Journal*, vol. 97, no. 4, pp. 341-358, 1997.
19. Davishahl, E., & Self, B. P., & Fuentes, M. P. (2021, July), WIP: Hands-On Statics in the Online “Classroom” Paper presented at 2021 ASEE Virtual Annual Conference Content Access, Virtual Conference. 10.18260/1-2—38087
20. S. Zolfaghari, T. Y. Rezaii, S. Meshgini, A. Farzamnia and L. C. Fan, "Speed Classification of Upper Limb Movements Through EEG Signal for BCI Application," in *IEEE Access*, vol. 9, pp. 114564-114573, 2021.
21. Sukumaran, B., Jahan, K., Dorland, D., Everett, J., Kadlowec, J., Gephardt, Z. and Chin, S., 2006. Engineering Clinics: An integration of research into the undergraduate engineering curriculum. *CUR quarterly*, 26(3), pp.115-121.