

Board 372: Research Initiation: Facilitating Knowledge Transfer within Engineering Curricula

Dr. Alexander John De Rosa, University of Delaware

Alexander De Rosa is an Associate Professor in Mechanical Engineering at The University of Delaware. He gained his Ph.D. in Mechanical Engineering from The Pennsylvania State University in 2015, where he worked on experimental combustion research applied to gas turbine engines, and his M.Eng. in Mechanical Engineering from Imperial College London in 2010. Alex's current research focuses on the transfer of learning between various courses and contexts and the professional formation of engineers.

Dr. Teri Kristine Reed, OU Polytechnic Institute

Teri K. Reed is the inaugural Director of the OU Polytechnic Institute and Professor and George Kaiser Family Foundation Chair at OU-Tulsa.

Samuel Van Horne, University of Delaware

Dr. Angela E. Arndt, Tech Literacy Services

Angela E. Arndt of Tech Literacy Services is an independent Educational Researcher and Program Evaluator serving engineering programs in higher education to improve academic success and increase diversity and inclusion.

Research Initiation: Facilitating Knowledge Transfer within Engineering Curricula

Introduction

The challenges engineering students face with transferring theory and skills across courses in the undergraduate curriculum, and eventually into the workplace, are well established [1-4]. At the same time, however, many courses within undergraduate curricula are still taught in silos or outside the major of the student. As such, the connections between courses and how material learned in one class might apply in other contexts are often neglected or not well understood by the students. More work is required to better enable students to transfer their learning and to form engineers who are adaptable and ready to face the interdisciplinary workplace they will enter upon graduation [5-9].

Literature in both the cognitive and engineering education fields discusses the difficulty students have with transferring knowledge, as well as the need to develop new teaching practices that aid students in developing cross-course connections and that promote the transfer of knowledge between different applications. For example, student difficulties in applying mathematical concepts such as integration to new problems have been discussed [10]. Weaving these fundamental mathematical concepts throughout the curriculum, as well as making explicit the connection between applications and showing example applications and their similarities to problems encountered in other situations have been suggested as potential remedies to aid students in transferring this knowledge [11-14]. Within the engineering and physics communities, several authors have shown that students' lack of deeper conceptual understanding presents a barrier to the successful transfer of knowledge between contexts in subjects ranging from statics [15,16] to thermodynamics [17-22]. The idea of priming or activating prior knowledge such that students see the connections to prior courses and can transfer this learning was discussed but not investigated [17].

The overall goal of this study is to answer the following research questions (RQs):

1. What are the primary challenges experienced by students when tasked with transferring theory and skills from prior courses, specifically mathematics and physics?
2. What methods of prior knowledge activation are most effective in enabling students to apply this prior knowledge in new areas of study?

Here we present a summary, to date, of the findings of this investigation. These findings are based on an analysis of the problem solving techniques employed by students in various years of their undergraduate program as well as faculty experts. A series of $n=23$ think-aloud interviews have been conducted in which participants were asked to solve a typical engineering statics problem that also requires mathematical skills to solve. Based on participant performance and verbalizations in these interviews, various barriers to the knowledge transfer process were

identified (lack of prior knowledge, accuracy of prior knowledge, conceptual understanding, lack of teaching of applications, language of problem, curricular mapping). At the same time, several interventions designed to promote the transfer of knowledge were incorporated into the interviews and tested. Initial results demonstrated the potential effectiveness of these interventions (detailed in the poster and other works resulting from this study) but questions were raised as to whether participants truly understood the underlying concepts they were being asked to transfer or whether they were able to copy the pattern of the solution in the context of the problem they were being asked to solve.

Methodology

A steel plate ($\gamma=490 \text{ lb/ft}^3$) has a thickness of 0.5 in and is supported by a pin at A and a rope at B. Determine the magnitude of the reaction forces at the pin and the tension in the rope.

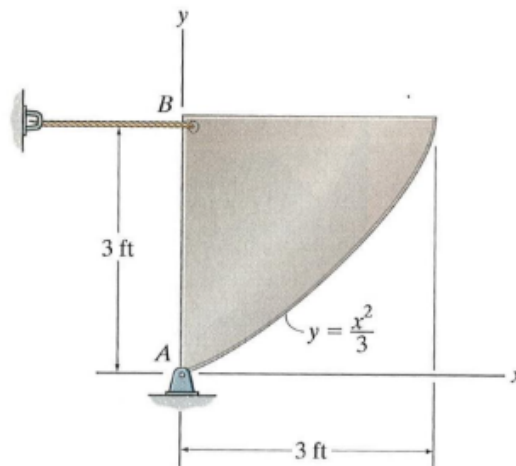

Figure 1: Engineering statics problem used in think-aloud interviews [23].

A semi-structured think-aloud interview protocol [24-27], based around solving a typical engineering statics problem, was developed in order to assess the barriers students faced in transferring knowledge. The particular problem that students were asked to solve is detailed in Fig.1. This problem is technically classified as a rigid body equilibrium problem and is common to engineering statics courses taught across a range of disciplines. Importantly for this study, the problem requires the successful transfer of mathematical skills such as integration to solve completely - both the area of the plate and the location of its centroid must be determined via the use of integration. The framework of knowledge transfer developed by Belenky & Nokes [28,29] was used as a guide to the problem solving process of the participants as it agreed with the authors own conceptions of the knowledge transfer process. This framework breaks the knowledge transfer process into several stages that allow for the development of questions and prompts within the interview process to examine participant behaviors.

Participants were sampled following a multi-level (nested) design in which mechanical engineering students from various years of study were asked to participate, as well as engineering course instructors (faculty). Selection of participants was based on responses to an

email and verbal recruitment campaign. Initially a series of n=11 think-aloud interviews were completed with a range of mechanical engineering students (n=9) and faculty (n=2) in order to examine both expert (faculty) and novice (student) approaches to solving the problem and to identify where (if anywhere) participants struggled to solve the problem.

Centroid of a Volume. If the body in Fig. 9-3 is made from a homogeneous material, then its density ρ (rho) will be constant. Therefore, a differential element of volume dV has a mass $dm = \rho dV$. Substituting this into Eqs. 9-2 and canceling out ρ , we obtain formulas that locate the *centroid C* or geometric center of the body; namely

$$\bar{x} = \frac{\int_V \tilde{x} dV}{\int_V dV} \quad \bar{y} = \frac{\int_V \tilde{y} dV}{\int_V dV} \quad \bar{z} = \frac{\int_V \tilde{z} dV}{\int_V dV} \quad (9-3)$$

These equations represent a balance of the moments of the volume of the body. Therefore, if the volume possesses two planes of symmetry, then its centroid must lie along the line of intersection of these two planes. For example, the cone in Fig. 9-4 has a centroid that lies on the y axis so that $\bar{x} = \bar{z} = 0$. The location \bar{y} can be found using a single integration by choosing a differential element represented by a *thin disk* having a thickness dy and radius $r = z$. Its volume is $dV = \pi r^2 dy = \pi z^2 dy$ and its centroid is at $\tilde{x} = 0, \tilde{y} = y, \tilde{z} = 0$.

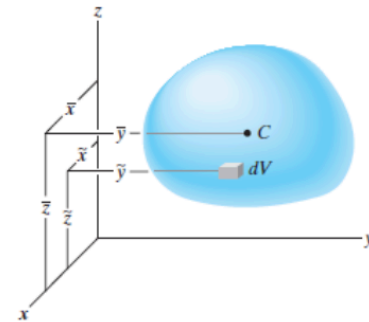
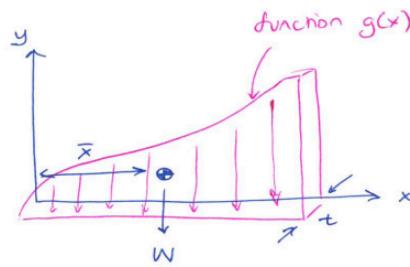

Fig. 9-3

(a) Equation based prompt from Statics textbook [23]

Finding the location of the centroid...



→ uniform plate made of homogeneous (same) material, γ is given, t is given

→ weight is essentially a distributed load relative to its height in $y \rightarrow g(x)$

$$\bar{x}W = \int_x g(x) \cdot x \, dW$$

$$\bar{x} = \frac{1}{A} \int x \cdot g(x) \, dx \quad \text{where } A = \int g(x) \cdot dx$$

(b) Prompt based on Statics course notes [30]

Figure 2: Prior knowledge prompts used in the second iteration of the study.

A second iteration of the interview protocol was then developed to allow for a prior knowledge prompt to be included in the problem solving process. This second series of interviews using a prompt was designed to assess the effectiveness of said prompt as a tool for activating prior knowledge and promoting problem solving success. Importantly, the prompt was only provided to the participants in the case that they needed help to solve the problem. A series of $n=5$ think-aloud interviews were completed using a purely mathematical prompt taken from an engineering statics textbook, and a series of $n=6$ think-aloud interviews were completed using a more applied prompt taken from the course notes of an engineering statics course. Both prompts are detailed in Fig.2. In this study using the prompt, undergraduate students from all years of the mechanical engineering program were recruited. In terms of the overall research population (initial and second iteration) representation was highest from second and third year students ($n=12$ sophomores, $n=7$ juniors, $n=2$ faculty). A total of nine women and thirteen men took part in the study.

Interview data consisted of both the written solutions to the problem created by the participants, as well as an audio recording of their verbalizations and the resulting transcript of the interview. These data were analyzed using thematic analysis with a provisionally determined rubric [31,32] based on the chosen knowledge transfer framework. Multiple investigators conducted the interviews and analyzed the resulting data before peer debriefing within the project team was used to develop and integrate the resulting themes and discuss patterns in the data.

Findings and Discussion

The initial interview protocol and data ($n=11$) that was analyzed to examine expert and novice approaches to problem solving were highly useful in demonstrating where student participants faced difficulties in transferring their knowledge and understanding. Findings indicated that students were successfully able to use integration to determine the area of the plate (see Fig.1) but were unable to find its centroid. Common reasons given by the participants for this inability were the lack of applications of centroids being taught or reinforced within the curriculum after they were initially taught. Student participants also displayed novice or rote approaches to solving the problem rather than following what might be considered a more logical, “engineering” problem solving approach grounded in fundamental theory and governing equations. Both the faculty participants ($n=2$), as well as the single student (male, sophomore) who came closest to the correct answer, displayed significant reflective practices in evaluating their solution at various stages of completion. Importantly, students suggested that seeing a reminder of how to calculate centroids in the form of an equation would be helpful in allowing them to solve the problem. As this idea correlated with suggestions in the literature concerning prior knowledge activation [17], the interview protocol was developed to include this mathematical prompt and a further series of interviews were conducted. Further information concerning this initial study of approaches to problem solving can be found in [33].

Findings from the interviews conducted using the mathematical prompt (n=5 undergraduate mechanical engineering students) further demonstrated the lack of understanding of centroids and their determination on the part of the student participants. Only one student (male, sophomore) was able to fully solve the statics problem correctly without the aid of the equation-based prompt. The other four students could not solve the problem, even when the prompt was supplied to them. Again, students referred to only examining simple shapes for which the centroid was easily determined or could be found using look-up tables as being a major factor in their inability to determine the centroid of the more complex geometry used in this study. When asked about the helpfulness of the equation based prompt, student participants were generally united in their thoughts that a more applied version of the prompt would have been more helpful to them in solving the problem. As such, the prompt was further refined to use course notes from the engineering statics class the participants would have taken previously and a new sample of students were recruited to the study to examine this new approach.

A total of six undergraduate students (5 sophomores, 1 junior, all male) participated in think-aloud interviews using the applied prompt. All of the students required the prompt to be provided at some stage in order to make further progress towards solving the problem. Only four of the students were able to completely solve the problem, however. Again, all students solved for the area of the plate using integration but the determination of the centroid was again the major barrier to problem solving success. Four participants were able to find the correct numerical answer to the statics problem after provision of the applied prompt, but it was unclear if they truly understood the equations and concepts they were using at a more fundamental level or whether they were simply able to copy the pattern of the prompt in their solution. A distinct lack of reflective or evaluative practice on behalf of the students was also observed, even when participants were prompted to examine the correctness of their solution. Further detail concerning the nature and effectiveness of the two prompts discussed here is being presented in our other work at this conference [34].

As well as reflection on the part of the participants appearing to be correlated with problem solving success, another issue that was prevalent in a majority of student solutions was incorrect usage and understanding of the English system of units. Many students mixed up the specific gravity (γ) and density (ρ) of the plate and had problems determining the weight of the plate in English units as they tended to follow an SI approach where multiplication by gravity is required and a one-to-one relationship in units is observed. This lack of a basic understanding of units displayed more fundamental problems that posed a barrier to students solving the problem and which must be remedied in addition to the issues faced by the students in determining the location of the centroid.

RQ1: Challenge	Observation	Solution	Context / Discussion
Lack of prior knowledge	Some students clearly did not have the prior knowledge required to transfer and solve the problem.	Reteach material.	The intervention tested here is predicated on the idea that students have the correct prior knowledge to apply. If they do not then a prior knowledge prompt will be ineffective. A prior knowledge test could be used to gauge initial understanding.
Loss of prior knowledge	Some students retained only partial prior knowledge.	Reteach material.	
Inaccurate prior knowledge	Some students displayed inaccurate (incorrect) prior knowledge.	Correct the knowledge.	Provision of a prompt seems to be effective in this case assuming it reminds students of the “missing piece of the puzzle”.
Lack of conceptual understanding	Participants demonstrated the ability to solve the problem but it was not clear that they understood what they were doing or why.	Assess conceptual understanding and revisit if incorrect.	Requires use of concept inventories or similar and is less about knowledge transfer than it is about assessing the accuracy of prior knowledge.
Lack of applications being taught	Students made reference to learning skills in a math context but not using them in engineering.	Teach applications of fundamental concepts/skills..	This is a potential area where prompting prior knowledge in the correct way might be effective in promoting problem solving success - some aspect of the prior knowledge exists within the participant that could be prompted.
Material not revisited since being taught	Centroids as a topic were found to be one that was initially taught but not revisited in a mathematical frame - further use often involved tabulated data or other non-mathematical solutions.	Weave material throughout the curriculum. Demonstrate links to prior material in other courses. Use tools such as concept mapping to make course links explicit.	
Instructor presents negative view of material	Students commented that the instructor of the prior course told them they “would not need to solve a problem this way again”.	Instructors should be discouraged from (a) talking this way about material as it disincentivizes learning or, (b) teaching material that is extraneous or unimportant.	If the instructor of a prior course tells students that material is not going to be used again - why would they pay attention to it? Likely leads to (1) lack of prior knowledge.
Modern solution techniques	Some participants commented that the centroid can be calculated using CAD, tabulated data, online tools, etc. that discourage or negate the need for learning the basic math skills required in this problem.	Allow solutions that involve the application of modern techniques and open up the solution space to utilize more realistic tools..	There is an argument to be made that conceptual understanding is important even if achieving the solution is not - students still need to set up a problem correctly. Reflective skills seem important in this regard.
Language of engineering	Many issues were observed with incorrect usage of English units, particularly in the context of density being used to find the weight.	Present students with examples that clearly demonstrate units used and which focus on dimensional homogeneity throughout the curriculum.	Additional cognitive load is applied when students cannot determine the units, or, they proceed using incorrect values based on an incorrect understanding. This load must be reduced to promote problem solving success.
Variation in approach to problem solving	Various participants solved for unknown values before knowing how they would be used or inferred the need to find various values based on how the problem was presented rather than using an “engineering approach”.	Focus on problem solving methods and provide more authentic, open ended problems with less obvious cues or markers.	The problem solving approaches observed demonstrated a lack of deeper understanding of the problem at hand and a rote approach to problem solving.

Table 1: Summary of challenges faced in transferring knowledge (RQ1)

Summary of Findings

These findings, as well as others discussed in more detail in our other publications [3,4,33,34], are summarized and related to the initial research questions posed in this study as follows:

RQ1: *What are the primary challenges experienced by students when tasked with transferring theory and skills from prior courses, specifically mathematics and physics?*

- A lack of sufficient or correct prior knowledge on behalf of the participants that could be transferred was noted throughout this investigation. This lack of prior knowledge was observed as both a complete lack or a partial understanding or recollection of this information.
- A lack of conceptual knowledge and understanding of centroids was also observed in almost all student participants.
- Theory and equations relating to centroids is not reinforced or used in the curriculum after it is initially introduced.
- The language and symbols used by the students varied and incorrect usage of English units was widespread.

A major barrier to problem solving success was found to be one of several issues with the prior knowledge that participants were asked to transfer. Examples of these issues included a total lack of prior knowledge, a misunderstanding of that prior knowledge or only a partial recollection. These challenges students faced in transferring their prior knowledge are expanded on in Table 1 which details each challenge as well as potential solutions to each barrier to knowledge transfer. Clearly there is an issue with the deeper learning and understanding of these concepts that are not being retained by the students and that is then exacerbated by a lack of followup on these items in later courses. Future work will survey the literature concerning the challenges identified in Table 1 in order to generate a list of best practices that could be used to overcome them.

RQ2: *What methods of prior knowledge activation are most effective in enabling students to apply this prior knowledge in new areas of study?*

- In general, students were unable to solve the statics problem without some form of guidance in the form of a prompt.
- A purely mathematical, equation-based prompt was unsuccessful in promoting problem solving success.
- Four of six participants correctly answered the problem when a more applied prompt, based on prior class notes, was provided. It was unclear however if students truly understood the conceptual basis of this prompt or whether they were able to copy its pattern to solve the problem.
- Reflective practices were observed to be effective in helping participants to solve the problem.

A purely mathematical prior knowledge prompt was ineffective in promoting knowledge transfer and it was unclear if an applied prompt was actually effective or whether students could copy the pattern in the solution without understanding it. Reflective practices were seen to be important in student problem solving success. Future work will examine student understanding of the material supplied in the prompts to determine whether they truly understand the concepts being highlighted and will also attempt to examine the role of reflective practice in problem solving success.

Conclusion

In order to examine and remedy the problems engineering students face in transferring knowledge between their classes and eventually, into their careers, a series of think-aloud, problem solving interviews were completed in order to both examine the barriers students face when asked to transfer knowledge. Based on a survey of the literature, an intervention based on priming and prompting prior knowledge was then developed with the goal of aiding students in transferring their prior knowledge to the current context and promoting problem solving success.

Initial findings of this work indicate that students possess inaccurate or incomplete prior knowledge of the physical and mathematical concepts that are often required to solve engineering problems. A lack of conceptual understanding of these concepts was also observed. It was suggested by the participants of this study that the absence of revisiting various concepts and ideas throughout the curriculum, after they are initially taught, could be partially responsible for these issues with knowledge transfer. Additionally, student misconceptions and incorrect applications of English units were observed along with a lack of following a logical, engineering problem solving process. There is also an indication that reflective and evaluative practices, at various stages of the problem solving process, could be useful in promoting problem solving success as these behaviors were observed in the most successful participants but not in the students who failed to solve the problem.

Future work will focus on:

1. Examination of the conceptual understanding of centroids held by students
2. Investigating the importance of reflection in the problem solving process
3. Categorizing students and dispositions that allow for problem solving success

As an initial barrier to problem solving success appears to be the lack of understanding of centroids held by students, the initial stage of future work will attempt to close the loop in this regard and examine the context in which students understand centroids and why their prior knowledge might be insufficient in this regard. A limited series of think aloud interviews focusing purely on centroids will be conducted to assess this understanding and develop a clearer idea as to accuracy of students prior knowledge of this topic.

Work to date has also highlighted the importance of reflection and evaluative practice in promoting problem solving success. This aspect of the solution process will also be investigated in further detail by surveying participants in various dimensions that could be thought of as linked to reflective practice (e.g. metacognition, a willingness to take on multiple perspectives, etc.) and correlating these dimensions with problem solving success. Comparisons will also be made between the reflective practices displayed by expert problem solvers and novices in order to reveal any potential differences in approaches and areas for improvement or learning on the part of novices. This work will also feed into the longer term goal of this project which will then aim to categorize students and dispositions that allow for problem solving success. For example, if we can determine that reflection, or intrinsic motivation, (for example) are critical aspects for success then future work by our group or others could focus on developing these dispositions in students or would lend weight to existing best practices for doing so.

Acknowledgements

Support for this work was provided by the National Science Foundation under Award No. 2301341. Any opinions, findings, and conclusions or recommendations expressed in this material are those of the author(s) and do not necessarily reflect the views of the National Science Foundation. Research work was conducted under institutional IRB protocols, IRB#1965654.

References

1. J. D. Bransford and D. L. Schwartz, "Chapter 3: Rethinking Transfer: A Simple Proposal With Multiple Implications," *Rev. Res. Educ.*, vol. 24, no. 1, pp. 61–100, Jan. 1999, doi: 10.3102/0091732X024001061.
2. D. K. Detterman and R. J. Sternberg, *Transfer on trial: Intelligence, cognition, and instruction*. Westport, CT, US: Ablex Publishing, 1993, pp. vi, 296.
3. De Rosa, A. J. (2020, June). Examining Knowledge Transfer Between Thermodynamics and Mathematics. In 2020 ASEE Virtual Annual Conference Content Access. Accessed: Jan. 29, 2024. [Online]. Available: <https://peer.asee.org/examining-knowledge-transfer-between-thermodynamics-and-mathematics>
4. De Rosa, A. J., Serbin, D., & Lee, S. (2019, November). Facilitating Cross-Course Connections & Knowledge Transfer between Engineering Thermodynamics and Mathematics (WIP). In 2019 Fall Mid Atlantic States Conference. Accessed: Jan. 29, 2024. [Online]. Available: <https://peer.asee.org/facilitating-cross-course-connections-knowledge-transfer-between-engineering-thermodynamics-and-mathematics-wip>
5. ABET, "Criteria for Accrediting Engineering Programs, 2020 – 2021 | ABET," ABET, 2021. <https://www.abet.org/accreditation/accreditation-criteria/criteria-for-accrediting-engineering-programs-2020-2021/> (accessed Jan. 29, 2024).

6. Moghaddam, Y., Demirkan, H. and Spohrer, J. T-Shaped Professionals: Adaptive Innovators. Hampton, NJ: Business Expert Press, 2018.
7. N. A. of Engineering and N. A. of Engineering, The Engineer of 2020: Visions of Engineering in the New Century. Washington, DC: The National Academies Press, 2004. doi: 10.17226/10999.
8. ASEE, Transforming Undergraduate Education in Engineering: Phase 1 Synthesizing and Integrating Industry Perspectives, ASEE, 1, May 2013. Accessed: Jan. 29, 2024. [Online]. Available: <https://tuee.asee.org/phase-i/report/>
9. Van der Heijden, B. (2002). Prerequisites to guarantee life-long employability. *Personnel review*, 31(1), 44-61. doi: 10.1108/00483480210412418.
10. Orton, A. (1983). Students' understanding of integration. *Educational studies in mathematics*, 14(1), 1-18. doi: 10.1007/BF00704699.
11. Rebello, N. S., Cui, L., Bennett, A. G., Zollman, D. A., & Ozimek, D. J. (2017). Transfer of learning in problem solving in the context of mathematics and physics. In *Learning to solve complex scientific problems* (pp. 223-246). Routledge.
12. Cui, L., Rebello, N. S., & Bennett, A. G. (2006, February). College students' transfer from calculus to physics. In *AIP Conference Proceedings* (Vol. 818, No. 1, pp. 37-40). American Institute of Physics. doi: 10.1063/1.2177017.
13. Rebello, N. S. (2013). Facilitating Transfer of Learning and Problem Solving in Physics. *Bulletin of the American Physical Society*, 58.. Available:<https://meetings.aps.org/Meeting/PSF13/Session/E1.4>
14. Schoenfeld, A. H. (2014). *Mathematical problem solving*. Elsevier. Accessed: Jan. 29, 2024. [Online]. Available: <https://www.elsevier.com/books/mathematical-problem-solving/schoenfeld/978-0-12-628870-4>
15. Passmore, L., & Litzinger, T., & Masters, C. B., & Turns, S., & Van Meter, P., & Firetto, C., & Zappe, S. (2010, June), Sources Of Students' Difficulties With Couples And Moments In Statics Paper presented at 2010 Annual Conference & Exposition, Louisville, Kentucky. <https://doi.org/10.18260/1-2--16198>
16. Litzinger, T. A., Meter, P. V., Firetto, C. M., Passmore, L. J., Masters, C. B., Turns, S. R., & Zappe, S. E. (2010). A cognitive study of problem solving in statics. *Journal of Engineering Education*, 99(4), 337-353. <https://doi.org/10.1002/j.2168-9830.2010.tb01067.x>
17. Pollock, E. B., Thompson, J. R., and Mountcastle, D. B., "Student Understanding Of The Physics And Mathematics Of Process Variables In P-V Diagrams," *AIP Conf. Proc.*, vol. 951, no. 1, pp. 168–171, Nov. 2007, doi: 10.1063/1.2820924.
18. Loverude, M. E., Kautz, C. H., & Heron, P. R. (2002). Student understanding of the first law of thermodynamics: Relating work to the adiabatic compression of an ideal gas. *American journal of physics*, 70(2), 137-148. doi: 10.1119/1.1417532.

19. Meltzer, D. E. (2004). Investigation of students' reasoning regarding heat, work, and the first law of thermodynamics in an introductory calculus-based general physics course. *American Journal of Physics*, 72(11), 1432-1446.
20. Christensen, W. M., & Thompson, J. R. (2010). Investigating student understanding of physics concepts and the underlying calculus concepts in thermodynamics. In *Proceedings of the 13th Annual Conference on Research in Undergraduate Mathematics Education*, Mathematical Association of America. Accessed: Jan, 29, 2024. [Online]. Available: <https://ui.adsabs.harvard.edu/abs/2010APS..MARH42004T>
21. Ellis, G. W., Rudnitsky, A., & Silverstein, B. (2004). Using concept maps to enhance understanding in engineering education. *International Journal of Engineering Education*, 20, 1012-1021.
22. Ellis, G., & Turner, W. (2003, June). Helping students organize and retrieve their understanding of dynamics. In *2003 Annual Conference* (pp. 8-632). Accessed: Jan. 29, 2024. [Online]. Available: <https://peer.asee.org/helping-students-organize-and-retrieve-their-understanding-of-dynamics>
23. Hibbeler, R. C. (1997). *Engineering Mechanics: Statics*. 12th. Upper Saddle River, NJ: Pearson/Prentice-Hall.
24. Vygotsky, L. S. (1962). *Thought and language*. (E. Hanfmann & G. Vaker Eds., Trans.). Cambridge, MA: MIT Press.
25. Ericsson, K. A., & Simon, H. A. (1980). Verbal reports as data. *Psychological Review*, 87(3), 215–251.
26. Charters, E. (2003). The use of think-aloud methods in qualitative research: An introduction to think-aloud methods. *Brock Education Journal*, 12(2).
27. Cowan, J. (2019). The potential of cognitive think-aloud protocols for educational action-research. *Active Learning in Higher Education*, 20(3), 219-232. <https://doi.org/10.1177/1469787417735614>
28. Nokes-Malach, T. J., & Mestre, J. P. (2013). Toward a model of transfer as sense-making. *Educational Psychologist*, 48(3), 184-207. DOI: 10.1080/00461520.2013.807556
29. Nokes, T. J., & Belenky, D. M. (2011). Incorporating Motivation into a Theoretical Framework for Knowledge Transfer. *Psychology of Learning and Motivation*, 109–135. doi:10.1016/b978-0-12-387691-1.00004-1
30. Buckley, J. (2023). Centroids [Class handout]. University of Delaware, MEEG210.
31. Creswell, J. W., & Poth, C. N. (2016). *Qualitative inquiry and research design: Choosing among five approaches*. Sage publications.
32. Braun, C., Clarke, V., Hayfield, N., Davey, L., & Jenkinson, E. (2023). Doing reflexive thematic analysis. In S. Badger-Charleson & A. McBeath (Eds.) *Supporting research in counseling and psychotherapy* (pp. 19–38).
33. De Rosa, A. J., & Reed, T. K., & Arndt, A. E. (2023, June), *Work in Progress: Promoting the Transfer of Math Skills to Engineering Statics*. Paper presented at 2023 ASEE Annual Conference & Exposition, Baltimore, Maryland. 10.18260/1-2--44334

34. De Rosa, A. J., Van Horne, S., Reed, T. K., & Arndt, A. E. (2024, June). Promoting the Transfer of Math Skills to Engineering Statics. Paper accepted into 2024 ASEE Annual Conference & Exposition, Portland, Oregon.