

The Role of Spatial Ability in a Statics and Mechanics of Materials Course

Dr. Maxine Fontaine, Stevens Institute of Technology

Maxine Fontaine is a Teaching Associate Professor in Mechanical Engineering at Stevens Institute of Technology. She received her Ph.D. in 2010 from Aalborg University in Aalborg, Denmark. Maxine has a background in the biomechanics of human movement, and

The Role of Spatial Ability in a Statics and Mechanics of Materials Course

Abstract

Strong spatial visualization skills are critical to success in engineering. Examples of spatial tasks include visualizing the 3D object that results from folding up a flat pattern or the 2D cross-section that results from cutting a 3D object or the 2D orthographic views of a 3D object. While spatial ability is clearly relevant to an engineering graphics course, studies have indicated that higher performance in math and chemistry courses also correlate with higher spatial skill level. The correlation between spatial ability and performance in a statics or other engineering mechanics course however is less clear. More data are needed to provide stronger conclusions in this area.

By identifying the role of spatial reasoning in engineering mechanics courses, like statics and mechanics of materials, instruction of these courses can be supplemented with practice problems that are designed to build spatial skills as needed. Spatial visualization skills have been shown to be significantly improved with a relatively short period of targeted practice.

This study aims to study the relationship between spatial ability and mastery of statics concepts. Since overall course grades are often confounded by other factors such as attendance or effort-based assignments, they may not be representative of the student's comprehension of the material. Scores for quiz and exam problems are used to measure mastery of various statics concepts. In the course, students completed one quiz problem each week to assess comprehension of the weekly topic. Every three weeks, students complete two exam problems to assess mastery of the last three weekly topics. Quiz problems were on average slightly less difficult than exam problems, as reflected in the overall average scores. A total of 8 quiz problems and 8 exam problems were completed over the course of the semester.

Since quiz and exam problems test specific concepts, this study also investigates whether the relationship is stronger for certain concepts than others, e.g. simpler fundamental concepts at the start of the semester vs. more advanced topics require integration of multiple concepts.

The Purdue Spatial Visualization Test: Rotations (PSVT:R) is a timed standardized test of mental rotations commonly used to assess spatial ability. The passing threshold is typically set at 60% or 70% to identify students with low spatial ability. At Stevens Institute of Technology, thresholds of 70% and 80% are used to separate students into groups of low, medium, and high spatial ability. The performance of these three groups in the statics course are compared using one-way ANOVA.

Preliminary results indicate significant differences between the high spatial ability and lower spatial ability groups for specific concepts that require thinking in more than two dimensions, such as bending stresses, and specific problems that require more complex free-body diagrams.

Introduction

The link between strong spatial visualization skills (SVS) and success in engineering is well established [1], [2]. Higher spatial ability has been correlated with higher performance in math, physics and chemistry [3-6]. Although underrepresented groups, such as women, are disproportionately affected by low spatial ability [7], these skills are learnable and can be improved significantly within a relatively short time period [6], [8].

The importance of SVS is more apparent in a course like engineering graphics, which relies on the ability to use 2D views to visualize in 3D for building solid models in CAD (e.g. extrude, revolve) as well as interpreting orthographic views on engineering drawings. The need for strong SVS in mechanics courses, such as statics and/or mechanics of materials, may be less obvious on the surface, but a closer look into the skills required to solve statics problems may provide some insight into the role of SVS in these courses.

The free body diagram (FBD) is often a critical preliminary step in solving statics problems. Sorby et al. [9] found that students with low SVS had difficulty interpreting word problems into the critical mathematical expressions and/or the free body diagrams needed to solve. They found a strong correlation between spatial ability and properly drawing FBDs, especially reaction forces at the supports. This ability to convert or frame a given problem into diagrams to visualize a path to a solution is also referred to as representational competence.

The concept of representational competence could play a key role in explaining the relationship between SVS and mastery of statics / mechanics of materials topics [10]. This construct describes the ability to think and communicate via visual representations of the problem, such as free-body diagrams. Students who rely solely on equations and algebraic manipulations may be able to perform well in the course to some extent but would lack a deep understanding of the underlying concepts that a more representational approach would afford.

Wood et al. [11] demonstrated a significant improvement in spatial ability of students before and after taking a statics course, indicating that students are using and developing their SVS as they progress through the course. Helweg [12] performed a small study to investigate using spatial ability as a predictor of success in a statics course, finding only a weak correlation. Success in the statics course was measured using the overall course grade, which may not accurately represent student mastery of course topics, especially if participation and other effort-based grades are included.

This study aims to explore the relationship between SVS and performance in a Statics & Mechanics of Materials course. Students are divided into three groups based on spatial ability: low, medium, and high. Test scores for these three groups are compared and analyzed through one-way ANOVA.

Methods

As part of the engineering core curriculum at Stevens Institute of Technology, all engineering students are required to take Statics and Mechanics of Materials (usually in term 3). In fall 2021, all students enrolled in this course (n=283) took common assessments, a total of 8 quizzes and 4

exams over the course of the semester, plus the final exam at the end of the semester. Each quiz consisted of 1 problem, and each exam consisted of 2 problems. The final exam consisted of 5 problems. Weekly quizzes were 24% of the course grade (best 5 of 8), and exams were 30% of the course grade (best 6 of 8 problems). The final exam was 26% of the course grade. Each quiz or exam problem was graded using a common grading rubric via Gradescope and completed by at most two teaching assistants to reduce grading inconsistencies. All problems were graded on a 10-point scale.

As shown in the assessment schedule in **Table 1**, the course was roughly divided into four units, where students were tested on each unit with two quizzes followed by an exam on a similar (if not identical) set of topics. For convenience, the first and second units will be referred to as Basic Statics and Basic Solid Mechanics, while the third and fourth units will be referred to as Intermediate Statics and Intermediate Solid Mechanics. It should be noted that all statics problems were 2D and not 3D. All quiz and exam problems are provided in the appendix.

Table 1. Schedule of assessments, two quizzes followed by an exam.

Unit	Week	Assessment	Topic
Unit 1. Basic Statics	2	Quiz 1	Force Vectors (2D)
	3	Quiz 2	Moment of a Force (2D)
	4	Exam 1, Problem 1	Equivalent Systems (2D)
	4	Exam 1, Problem 2	Equilibrium (2D)
Unit 2. Basic Solid Mechanics	5	Quiz 3	Normal and Shear Stress
	6	Quiz 4	Mechanical Properties, Multiaxial Deformation
	7	Exam 2, Problem 1	Equilibrium, Allowable Stress
	7	Exam 2, Problem 2	Axial Load and Deformation, Compatibility
Unit 3. Intermediate Statics	8	Quiz 5	Trusses
	9	Quiz 6	Frames
	10	Exam 3, Problem 1	Trusses
	10	Exam 3, Problem 2	Frames
Unit 4. Intermediate Solid Mechanics	11	Quiz 7	Shear Force and Bending Moment Diagrams
	12	Quiz 8	Bending Stress
	13	Exam 4, Problem 1	Shear Force and Bending Moment Diagrams
	13	Exam 4, Problem 2	Bending Stress

In this study, students were separated into three groups based on their spatial visualization skills (SVS), which was assessed about a year prior to taking the statics course. Spatial ability was measured using the Purdue Spatial Visualization Test: Rotations (PSVT:R) which is a standardized timed test of mental rotations [13]. All engineering students are required to take the test as part of the engineering graphics (usually in term 1). The course also contains spatial skill building activities over a 5-week period that are aimed at improving SVS in students with low spatial ability. Following this set of activities, students were given the option to retake the PSVT:R. Significant increases in test score were observed after this training period, as described in an earlier study [14]. The highest PSVT:R score attained by students during this first-semester course is used in this study.

Results

Students were divided into three groups, based on their PSVT:R score. The low SVS group had scores below 70%, the medium SVS group had scores from 70% to 79%, and the high SVS group had scores 80% or higher. In this cohort (n=283), 8% had low SVS, 29% had medium SVS, and 63% had high SVS, as seen in **Figure 1**.

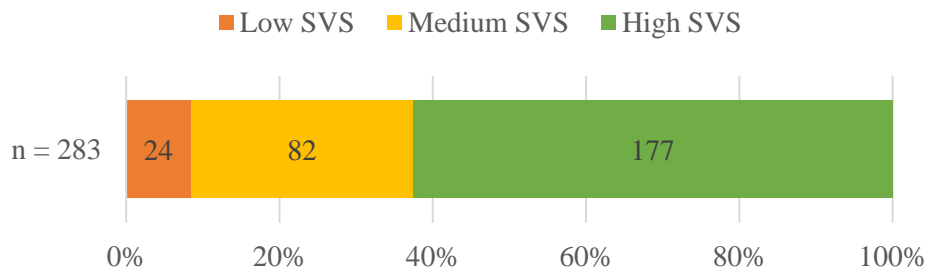

Figure 1. Distribution of students with low SVS, medium SVS, and high SVS.

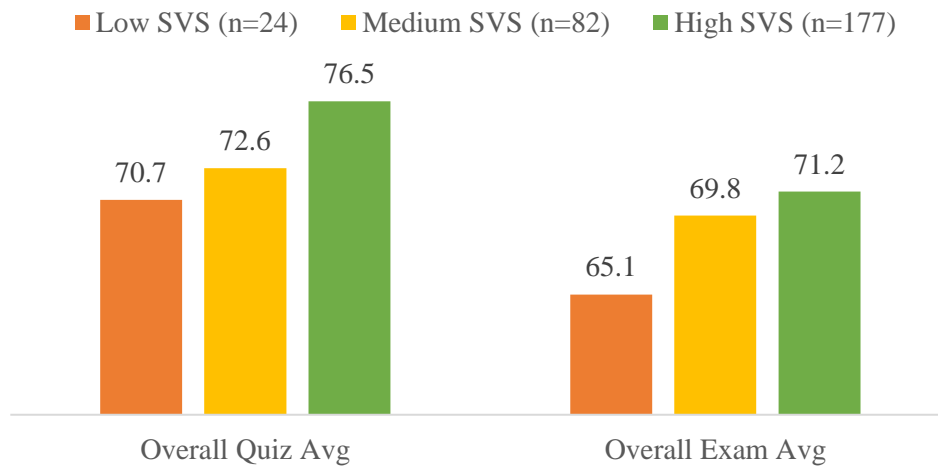

Figure 2. Overall quiz averages and overall exam averages for the low, medium, and high SVS groups.

Overall quiz averages and overall exam averages for the three groups are shown in **Figure 2**. Although the average scores appear to increase with spatial ability for both the quizzes and exams, a one-way ANOVA only indicates significant differences between groups for the overall quiz average ($F(2, 280) = 4.089, p = .018$), and not for the overall exam average ($F(2, 280) = 2.663, p = .072$). Detailed statistics are provided in **Table 2**.

Table 2. Descriptive statistics for overall quiz average and overall exam average among the low, medium, and high SVS groups.

	<i>n</i>	Overall Quiz Avg		Overall Exam Avg	
		<i>M</i>	<i>SD</i>	<i>M</i>	<i>SD</i>
Low SVS	24	70.7	2.61	65.1	2.52
Medium SVS	82	72.6	1.41	69.8	1.36
High SVS	177	76.5	0.96	71.2	0.93

A more detailed analysis was performed for each quiz problem and each exam problem. The mean scores for the low, medium, and high SVS groups on each problem are shown in **Figure 3** and **Figure 4**. For many problems, a slight increase in average score with spatial ability is observed, but most of these increases were not statistically significant. Significant differences ($p < .05$) in mean score between the groups were found in three problems (Q2, Q8, and E42), as indicated by a star.

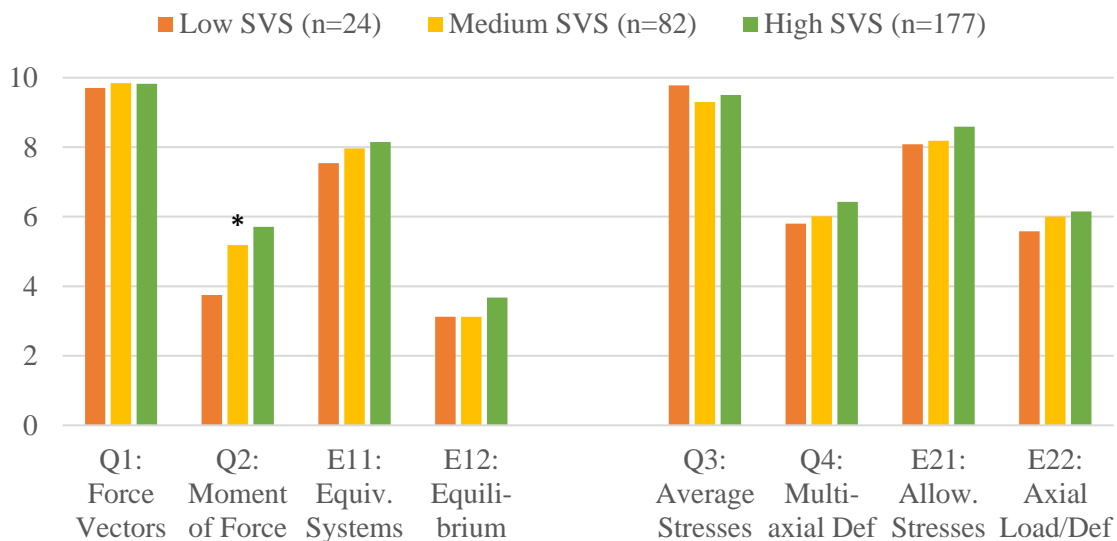

Figure 3. Average scores (out of 10) for the low, medium, and high SVS groups on each quiz and exam problem for Unit 1 (Basic Statics) and Unit 2 (Basic Solid Mechanics). A star indicates a significant difference between groups ($p < .05$).

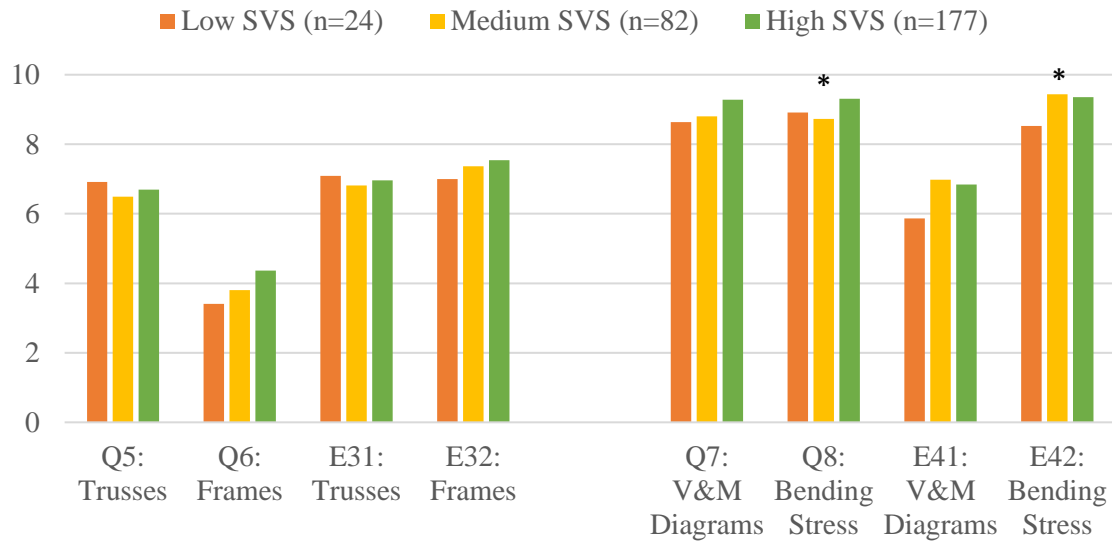

Figure 4. Average scores (out of 10) for the low, medium, and high SVS groups on each quiz and exam problem for Unit 3 (Intermediate Statics) and Unit 4 (Intermediate Solid Mechanics). A star indicates a significant difference between groups ($p < .05$).

One-way ANOVA results, summarized in **Table 3**, indicated significant differences between groups on only three problems: Q2 (moment of a force), Q8 (bending stress), and E42 (bending stress). Tukey’s HSD for multiple comparisons revealed significant differences in mean scores between low and high SVS groups on Q2. Post hoc tests also revealed that the medium-SVS group scored significantly lower than the high SVS group on Q8, and that both the low-SVS and medium-SVS groups scored significantly lower than the high SVS group on E42.

Table 3. One-way ANOVA results for each quiz problem and each exam problem (3 groups).

Problem	One-way ANOVA	Problem	One-way ANOVA
Q1	$F(2, 278) = 0.2387, p = 0.7878$	E11	$F(2, 279) = 1.7383, p = 0.1777$
Q2	$F(2, 268) = 3.0534, p = 0.0488 *$	E12	$F(2, 275) = 1.8315, p = 0.1621$
Q3	$F(2, 273) = 1.8241, p = 0.1633$	E21	$F(2, 275) = 1.9522, p = 0.1439$
Q4	$F(2, 266) = 0.7345, p = 0.4807$	E22	$F(2, 273) = 0.5035, p = 0.6050$
Q5	$F(2, 267) = 0.2883, p = 0.7497$	E31	$F(2, 275) = 0.1606, p = 0.8517$
Q6	$F(2, 271) = 2.9813, p = 0.0524$	E32	$F(2, 272) = 0.9587, p = 0.3847$
Q7	$F(2, 272) = 2.1427, p = 0.1193$	E41	$F(2, 266) = 1.8449, p = 0.1601$
Q8	$F(2, 268) = 3.7451, p = 0.0249 *$	E42	$F(2, 272) = 3.4740, p = 0.0324 *$

Since the sample size for the low-SVS group was rather small ($n=24$), another analysis was performed with just two groups: the high SVS group, and a combined low and medium SVS group. Results of this analysis are shown in **Figure 5** and **Figure 6**.

The results of the one-way ANOVA for these two groups, shown in **Table 4**, indicated significant differences between groups on four problems: E21 (allowable stresses), Q6 (frames), Q7 (shear force and bending moment diagrams), and Q8 (bending stress).

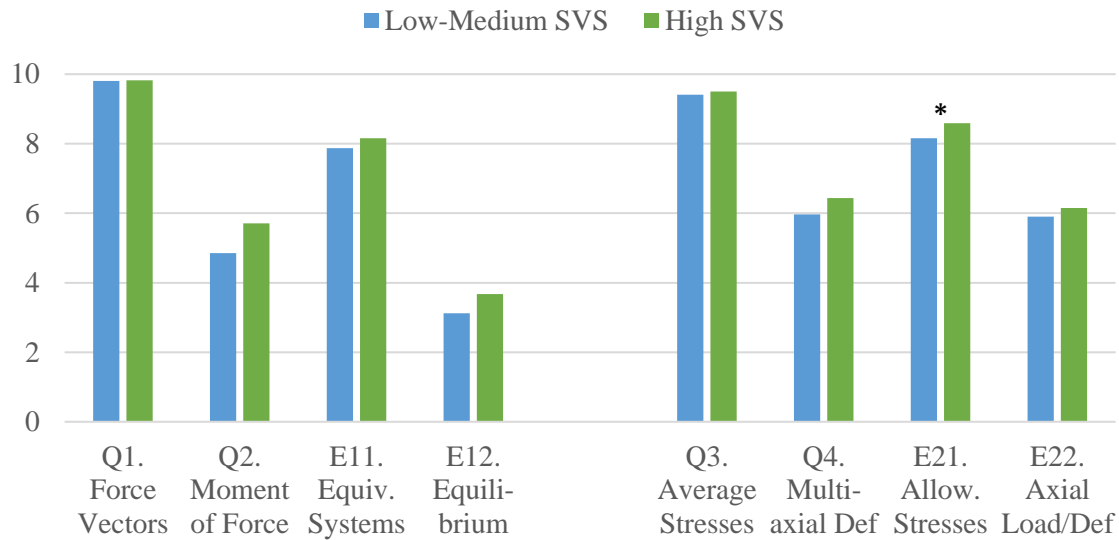

Figure 5. Average scores (out of 10) for the low/medium and high SVS groups on each quiz and exam problem for Unit 1 (Basic Statics) and Unit 2 (Basic Solid Mechanics). A star indicates a significant difference between groups ($p < .05$).

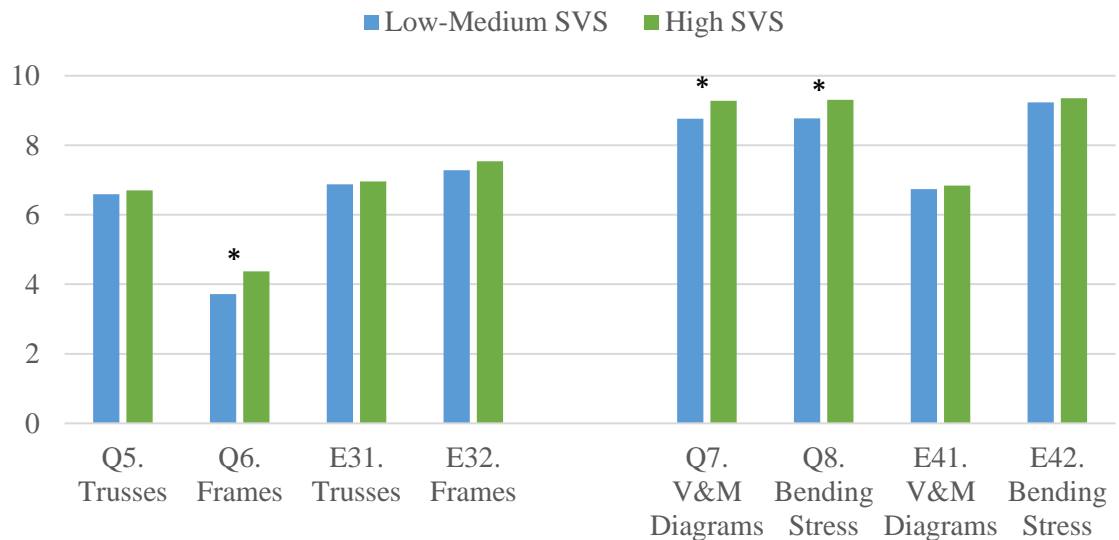

Figure 6. Average scores (out of 10) for the low/medium and high SVS groups on each quiz and exam problem for Unit 3 (Intermediate Statics) and Unit 4 (Intermediate Solid Mechanics). A star indicates a significant difference between groups ($p < .05$).

Table 4. One-way ANOVA results for each quiz problem and each exam problem (2 groups).

Problem	One-way ANOVA	Problem	One-way ANOVA
Q1	F(1, 279) = 0.0195, p = 0.8891	E11	F(1, 280) = 2.1536, p = 0.1434
Q2	F(1, 269) = 3.3508, p = 0.0683	E12	F(1, 276) = 3.6763, p = 0.0562
Q3	F(1, 274) = 0.4419, p = 0.5068	E21	F(1, 276) = 3.8599, p = 0.0505 *
Q4	F(1, 267) = 1.3955, p = 0.2385	E22	F(1, 274) = 0.5581, p = 0.4557
Q5	F(1, 268) = 0.1142, p = 0.7356	E31	F(1, 276) = 0.0830, p = 0.7735
Q6	F(1, 272) = 5.4368, p = 0.0204 *	E32	F(1, 273) = 1.2378, p = 0.2669
Q7	F(1, 273) = 4.1811, p = 0.0418 *	E41	F(1, 267) = 0.1213, p = 0.7279
Q8	F(1, 269) = 7.2956, p = 0.0074 *	E42	F(1, 273) = 0.4113, p = 0.5218

Discussion

Results did not indicate that spatial ability was more aligned with statics topics versus mechanics of materials topics. Instead, it appeared that problems involving specific concepts (e.g. bending stress) and specific skills (e.g. drawing a more complex free-body diagram) revealed the most significant differences between the groups.

Looking at the first set of problems covering basic statics topics (Unit 1), all groups performed well on the force vectors quiz (Q1), which simply required students to understand vector decomposition into x y components. In problems involving moment of a force (Q2, E11, and E12), average test scores generally increased with spatial ability, with a significant difference between the low-SVS and high-SVS group on Q2 (moment of a force). Students with low SVS may have difficulty visualizing the direction of the moment of a force, which is essential to solving these types of problems correctly.

In the second set of problems covering basic solid mechanics topics (Unit 2), all groups performed well on the quiz covering average normal stress and average shear stress (Q3), which required a very basic FBD of a simply supported beam. In the subsequent problems, students needed to draw a more complex FBD, and the results show that average test scores generally increased with spatial ability. A significant difference in test score was observed between the combined low/medium SVS group and high-SVS group on E21, where students needed to analyze a bell-crank and determine allowable stresses for the rod and pin.

For the third set of problems covering more intermediate statics applications such as trusses and frames (Unit 3), all groups performed similarly on trusses. In fact, the low-SVS group had the highest average score on both truss problems (Q5 and E31). Since truss analysis can be performed using method of joints and/or method of sections, students with lower SVS could potentially have utilized the former, which avoids the use of moments and rigid body FBDs. In frame analysis, however, drawing rigid body FBDs and writing moment equations are unavoidable. The high SVS group scored significantly higher than the combined low/medium group on the frame analysis quiz (Q6).

In the last set of problems covering more intermediate solid mechanics topics such as bending (Unit 4), there were significant differences seen in the majority of the problems. The high-SVS group scored significantly higher than the combined low/medium group on the shear force and bending moment (V & M) diagrams quiz (Q7) and the bending stress analysis quiz (Q8). Differences in the V & M diagrams were somewhat surprising, as no FBD was required (support reactions were provided) and students presumably could rely on math skills to generate these diagrams (using the graphical method). For bending stress analysis, students are required to track internal loading profiles and stress profiles along multiple dimensions, which conceivably requires an adequate level of SVS.

Conclusions and Future Work

Concepts such as moment equilibrium and bending stress may be more strongly linked to SVS than concepts like average stresses in uniaxial loading or shear loading. Students need to visualize the rotational effect of a force to understand moment equilibrium, and for bending stresses, students need to understand that normal stresses vary across the cross-sectional profile of the beam as well as along the axis of the beam. Spatial ability has also been linked to representational competence, which would be most directly related to drawing free-body diagrams in a statics and/or solid mechanics course.

Significant differences in average test scores between the low/medium-SVS and high-SVS groups emerged for allowable stress analysis, frame analysis, shear force and bending moment diagrams, and bending stress analysis. Since these two groups were formed using a relatively high threshold of 80% on the PSVT:R (passing threshold is typically 70% or even 60%), the fact that significant differences were still observed indicates that mechanics courses may require stronger SVS than courses that have been previously studied, such as math or chemistry.

One limitation of this study was the relatively small sample size for the low-SVS group (n=24). To determine the effects of low SVS on understanding concepts in statics and solid mechanics, more data is needed for this group. The sample size for this group will increase as data is collected each semester for this course.

Another potential issue within this study is that SVS may have improved over the course of the semester. Students were grouped based on their PSVT:R scores from another course, about a year prior to taking statics. Although it has been demonstrated that the statics course can improve SVS [11], students at Stevens were provided targeted practice during first-year engineering graphics course and saw significant gains in SVS after this training. In addition, a previous longitudinal study at Stevens indicated that SVS remain at similar levels from first-year (post-training) to final year [15]. Nonetheless it may be useful to reassess spatial ability using the PSVT:R at the end of the statics course.

Results from this preliminary study are indicative of a link between SVS and certain concepts in statics and solid mechanics. Further work is required to provide more conclusive results and to identify specific reasons to explain these trends. A better understanding of this relationship will inform how instructors can better prepare students with low SVS to succeed in these courses.

References

- [1] I. M. Smith, *Spatial ability: its educational and social significance*. San Diego, Calif.: R.R. Knapp, 1964.
- [2] J. Wai, D. Lubinski, and C. P. Benbow, "Spatial ability for STEM domains: Aligning over 50 years of cumulative psychological knowledge solidifies its importance," *J. Educ. Psychol.*, vol. 101, no. 4, pp. 817–835, 2009, doi: 10.1037/a0016127.
- [3] Carter, C. S., LaRussa, M. A., & Bodner, G. M. (1987). A study of two measures of spatial ability as predictors of success in different levels of general chemistry. *Journal of Research in Science Teaching*, 24(7), 645–657.
- [4] Tartre, L.A. (1990). Spatial skills, gender, and mathematics. In E. H. Fennema & G. C. Leder (Eds.), *Mathematics and Gender*, (pp. 27-59). New York, NY: Teachers College Press.
- [5] S. A. Sorby, "Spatial skills training to improve student success in engineering," *Chemistry*, vol. 1, no. 2.47, pp. 0–024, 2012.
- [6] S. A. Sorby, "Educational Research in Developing 3-D Spatial Skills for Engineering Students," *Int. J. Sci. Educ.*, vol. 31, no. 3, pp. 459–480, Feb. 2009, doi: 10.1080/09500690802595839.
- [7] M. C. Linn and A. C. Petersen, "Emergence and Characterization of Sex Differences in Spatial Ability: A Meta-Analysis," *Child Dev.*, vol. 56, no. 6, pp. 1479–1498, 1985, doi: 10.2307/1130467.
- [8] D. H. Uttal *et al.*, "The malleability of spatial skills: a meta-analysis of training studies," *Psychol. Bull.*, vol. 139, no. 2, pp. 352–402, Mar. 2013, doi: 10.1037/a0028446.
- [9] Sorby, S., & Duffy, G., & Soni, D., & Panther, G. (2022, August), An Evaluation of The Relationship between Spatial Skills and Creating a Free Body Diagram Paper presented at 2022 ASEE Annual Conference & Exposition, Minneapolis, MN.
<https://peer.asee.org/41680>
- [10] Davishahl, E., & Haskell, T., & Singleton, L., & Fuentes, M. P. (2021, July), Do They Need To See It To Learn It? Spatial Abilities, Representational Competence, and Conceptual Knowledge in Statics Paper presented at 2021 ASEE Virtual Annual Conference Content Access, Virtual Conference. <https://peer.asee.org/36990>
- [11] Wood, S. D., & Goodridge, W. H., & Call, B. J., & Sweeten, T. L. (2016, June), Preliminary Analysis of Spatial Ability Improvement within an Engineering Mechanics Course: Statics Paper presented at 2016 ASEE Annual Conference & Exposition, New Orleans, Louisiana. 10.18260/p.25942

- [12] Helweg, O. (2001, June), Using The Purdue Spatial Visualization Test To Predict Success In Statics. Paper presented at 2001 Annual Conference, Albuquerque, New Mexico. 10.18260/1-2—9984. <https://peer.asee.org/using-the-purdue-spatial-visualization-test-to-predict-success-in-statics>
- [13] R. Guay, Purdue Research Foundation, Educational Testing Service, and Test Collection, *Purdue spatial visualization test*. West Lafayette, Ind.: Purdue University, 1976.
- [14] Fontaine, M., & De Rosa, A. J. (2021, July), Implementation of a Nontraditional Spatial Skills Training Program. Paper presented at 2021 ASEE Virtual Annual Conference Content Access, Virtual Conference. <https://peer.asee.org/37297>
- [15] Fontaine, M., & De Rosa, A. J. (2020, June), Longitudinal Analysis of Spatial Ability over an Undergraduate Engineering Degree Program. Paper presented at 2020 ASEE Virtual Annual Conference Content Access, Virtual On line . 10.18260/1-2—34931

Appendix. Quiz Problems and Exam Problems for Statics & Mechanics of Materials

Quiz 1. Force Vectors

Consider the three vectors pictured to the right. Determine the following:

- The components of the resultant force vector
- The magnitude and direction of the resultant force vector (angle measured ccw from positive x-axis)

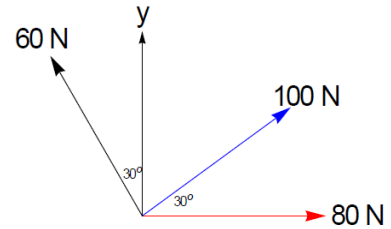

Quiz 2. Moment of a Force

Scenario 1. Assume that F_1 is 25 lbs. What is the moment at Point S?

Scenario 2. For a different Force F_1 , the moment caused at Point E is 408 lb-in clockwise. What is the value for F_1 in this case?

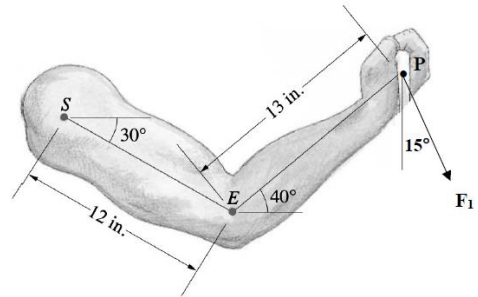

Exam 1, Problem 1. Equivalent Systems

The beam ABC is subjected to the planar force system as shown.

- Replace the force system by an equivalent force and couple acting at point C.
- Determine the location of the equivalent resultant force on the beam measured from point C.

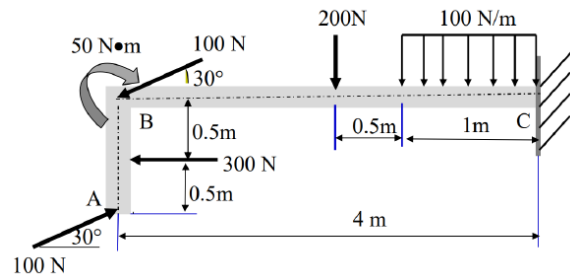

Exam 1, Problem 2. Equilibrium

The angle $\theta = 37^\circ$ as shown in the image below. Points A, B, and C are frictionless pin joints. At this angle the piston BA, a two-force member, exerts a force of 1150 lb at Point A. Assume that the direction of this force acts from Point B to Point A.

- What is the weight of the load W in pounds?
- What are the magnitude and direction of the resultant force acting at Pin C, measured with respect to the $+x$ axis?

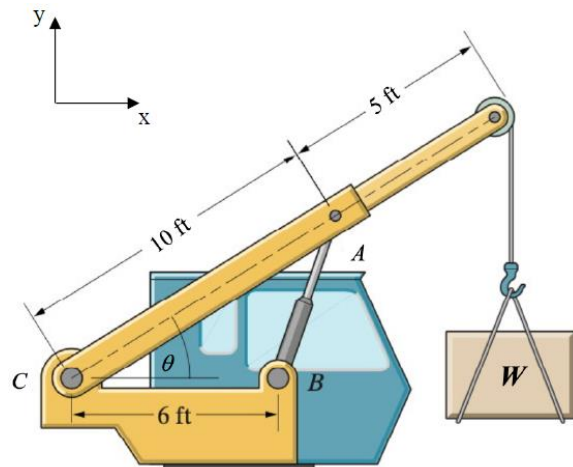

Quiz 3. Normal and Shear Stress

Consider the picture below. The load F is applied to the end of the beam which is supported by a cable at point B and a hinge at point A. The hinge at A has the pin in a double shear configuration. The maximum normal stress for the cable is 300MPa and the maximum shear stress for the pin is 200MPa.

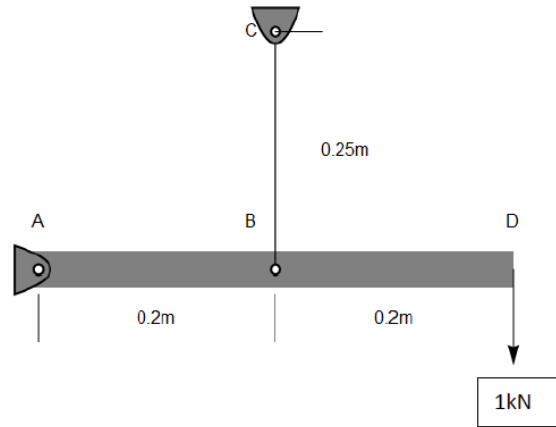

- Draw the free body diagram of the beam
- Find all reactions
- Determine the diameter for the cable BC
- Determine the diameter of the pin at A

Quiz 4. Mechanical Properties, Multiaxial Deformation

The 12 foot rigid beam shown in the figure below is supported by the steel wire CB (original diameter of wire before load is applied is 0.25 inches) and the pin at A. The steel wire has a modulus of elasticity of 29×10^3 ksi, a shear modulus of 11×10^3 ksi, and a yield strength of 50 ksi. For a distributed load $w=125$ lb/ft applied to the beam as shown below:

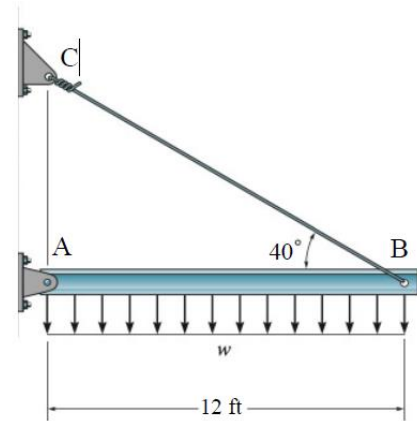

- Determine the factor of safety of the wire CB for the given load such that the wire does not yield
- Determine the new cross-sectional area of wire CB once the load is applied

Exam 2, Problem 1. Equilibrium, Allowable Stress

Consider the figure to the right, where a 5.5 kN force applied at Point B results in a horizontal force in the rod connected at Point C. This rod has a diameter of 7 mm prior to the application of the load. Calculate the following:

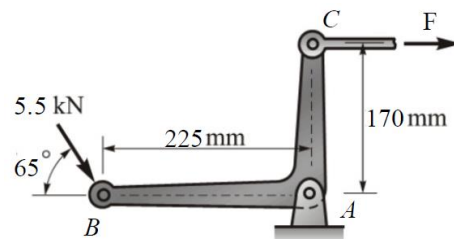

- Find the average normal stress in the rod connected at Point C. Be sure to clearly state if this is a tensile or compressive stress.
- If the Pin at A is in Double Shear, determine the minimum required diameter of the pin to the nearest mm needed to provide a factor of safety of 2.0 with respect to shear in the pin. The yield stress of the pin material in shear is 152 MPa.

Exam 2, Problem 2. Axial Load and Deformation, Compatibility

Consider the rigid beam supported by cables as shown. Each cable has a diameter of 7mm and is made of steel with a Young's modulus, $E=200\text{GPa}$.

- Determine the force in each cable
- Determine the normal stress in each cable
- Determine the angle of the beam relative to the horizontal

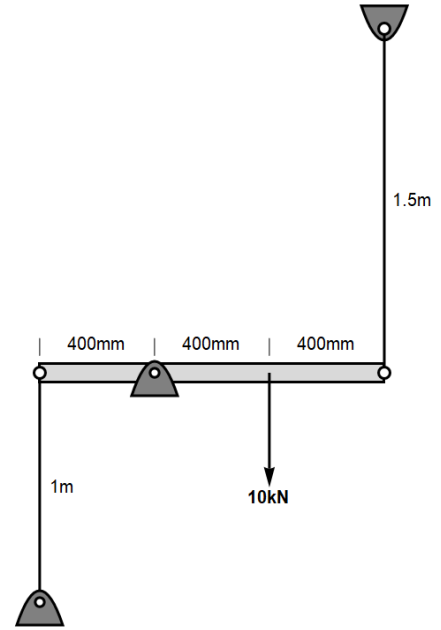

Quiz 5. Truss Analysis

For the truss problem shown below:

- Determine the forces (Magnitude, Tension or Compression) in members CD and BC
- Identify all zero-force members

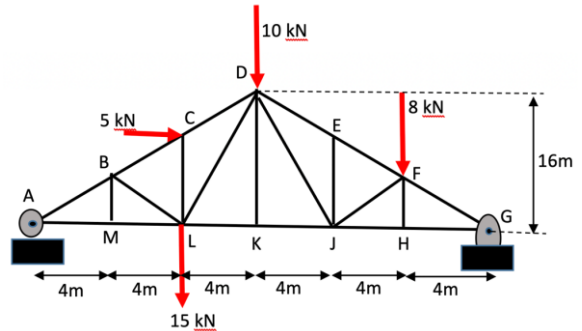

Quiz 6. Frame Analysis

For the frame shown below:

- Find all forces acting on member ABCD. Be sure to clearly mark the direction the force is acting in addition to the magnitude of the force.
- Clearly mark if member CE is in tension or compression

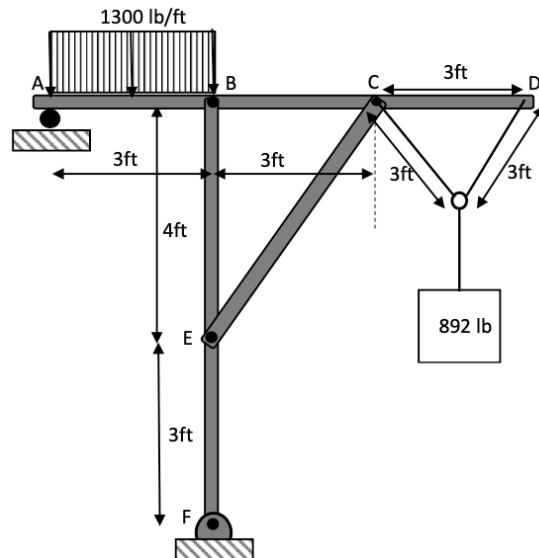

Exam 3, Problem 1. Truss Analysis

Consider the truss shown. Joints D and J are a pin and roller constraint, respectively.

- Find the external reactions at joints D and J
- Find the load in members FG, BF, AM and AG and state whether they are tension or compression

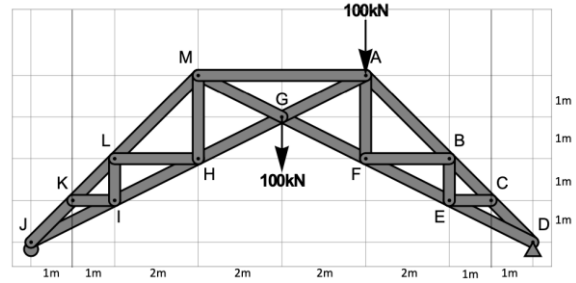

Exam 3, Problem 2. Frame Analysis

The force applied to the cable is $P = 250$ lb. Joints A, B, C, D, and E are pins. Determine the vertical and horizontal components of the reaction forces at joints A and E. (Hint: the horizontal distance from C to F is 5 inches.)

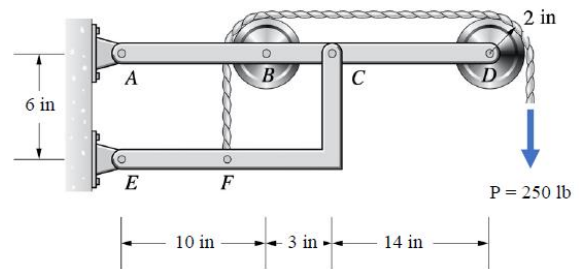

Quiz 7. Shear Force and Bending Moment Diagrams

For the beam shown below, the reactions at the supports at A and B have already been calculated (be careful with the direction of the forces as drawn on the figure). Given this information:

- Draw the shear force and bending moment diagrams.
- Label the magnitudes of the shear forces and bending moments on the diagrams.
- Identify the magnitude and location of the maximum shear force and the maximum bending moment.

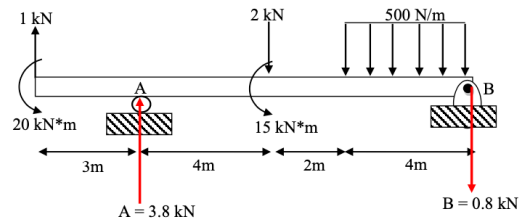

Quiz 8. Bending Stress

Consider the beam pictured below. To receive full credit you must show all work.

- Determine the maximum bending moment, M_{max} , in the beam and its location (x)
- Find the moment of inertia for the cross section of the hollow square tube, I
- Determine the maximum tensile stress and its location (x, y)

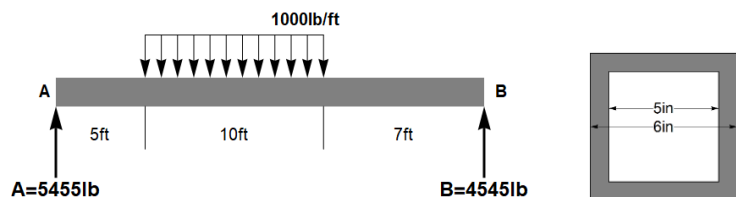

Exam 4, Problem 1. Shear Force and Bending Moment Diagrams

Consider the beam pictured below with a pin at A and a roller at B.

- Draw the Shear Force and Bending Moment Diagrams. (label all points)
- Determine the maximum magnitude of shear force and its location.
- Determine the maximum magnitude of bending moment and its location

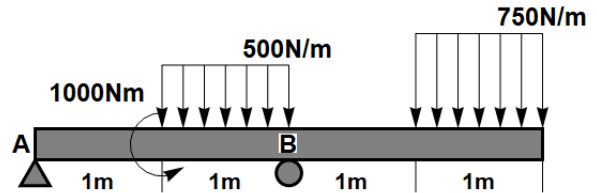

Exam 4, Problem 2. Bending Stress

For the beam loading shown below, you are provided a diagram of the cross-section of the beam and a sketch of the bending moment diagram. The neutral axis was found to be 0.239 m from the bottom of the cross-section as shown in the cross-section figure.

- Find the Moment of Inertia about the neutral axis (I_{NA}).
- Using the given bending moment diagram, find the maximum compressive stress and clearly indicate the coordinates where it occurs (x, y)
- Find the normal stress due to bending at Point A of the cross-section at $x = 0.5\text{m}$. Clearly indicate if this stress is tension or compression. (Hint: You may wish to section the beam at $x = 0.5\text{m}$ and evaluate the internal moment.)

