

## **Involving Multidisciplinary Undergraduate Students in the Design and Development of an Innovative Device for the Detection of Plant Nematodes**

### **Dr. Junkun Ma, Sam Houston State University**

Dr. Junkun Ma is currently a Professor of Mechanical Engineering Technology at Sam Houston State University (SHSU). He teaches mechanics of materials, manufacturing processes, CAD, applied fluid mechanics, etc., courses. His research interests include net-shape fabrication of sintered ceramics, numerical simulation using FEM, and engineering and technology education

### **Dr. Faruk Yildiz, Sam Houston State University**

Faruk Yildiz is currently a Professor of Engineering Technology at Sam Houston State University. His primary teaching areas are in Electronics, Computer Aided Design (CAD), and Alternative Energy Systems. Research interests include: low power

### **Dr. Reg Recayi Pecan, Sam Houston State University**

Dr. Reg Pecan is currently a Quanta Endowed Professor of the Department of Engineering Technology at Sam Houston State University in Huntsville, Texas. Dr. Pecan was formerly a professor and program chairs of Electrical Engineering Technology and Graduate (MS and Doctoral) Programs in the Department of Technology at the University of Northern Iowa (UNI). Dr. Pecan served as 2nd President and Professor at North American University in Houston, TX from July 2012 through December 2016. He also served as a Chair of Energy Conservation and Conversion Division at American Society of Engineering Education (ASEE). Dr. Pecan holds a B.S. in EE and an M.S. in Controls and Computer Engineering from the Istanbul Technical University, an M.S. in EE from the University of Colorado at Boulder, and a Ph.D. in Electrical Engineering from the University of Wyoming (UW, 1997). He served as a graduate assistant and faculty at UW, and South Dakota State University. He served on UNI Energy and Environment Council, College Diversity Committee, University Diversity Advisory Board, and Graduate College Diversity Task Force Committees. His research interests, grants, and more than 50 publications are in the areas of AC/DC Power System Interactions, distributed energy systems, power quality, and grid-connected renewable energy applications including solar and wind power systems. He is a senior member of IEEE, member of ASEE, Tau Beta Pi National Engineering Honor Society, and ATMAE. Dr. Pecan was recognized as an Honored Teacher/Researcher in "Who's Who among America's Teachers" in 2004-2009. Dr. Pecan is a recipient of 2010 Diversity Matters Award at the University of Northern Iowa for his efforts on promoting diversity and international education at UNI. He is also a recipient of 2011 UNI C.A.R.E Sustainability Award for the recognition of applied research and development of renewable energy applications at UNI and Iowa in general. Dr. Pecan established solar electric boat R & D center at UNI where dozens of students were given opportunities to design solar powered boats. UNI solar electric boat team with Dr. Pecan's supervision won two times a third place overall in World Championship on solar electric boating, an international competition promoting clean transportation technologies in US waters. He was recognized as an Advisor of the Year Award nominee among 8 other UNI faculty members in 2010-2011 academic year Leadership Award Ceremony. Dr. Pecan received a Milestone Award for outstanding mentoring of graduate students at UNI, and recognition from UNI Graduate College for acknowledging the milestone that has been achieved in successfully chairing ten or more graduate student culminating projects, theses, or dissertations, in 2011 and 2005.

He was also nominated for 2004 UNI Book and Supply Outstanding Teaching Award, March 2004, and nominated for 2006, and 2007 Russ Nielson Service Awards, UNI. Dr. Pecan is an Engineering Technology Editor of American Journal of Undergraduate Research (AJUR). He has been serving as a reviewer on the IEEE Transactions on Electronics Packaging Manufacturing since 2001. Dr. Pecan has served on ASEE Engineering Technology Division (ETD) in Annual ASEE Conferences as a reviewer, session moderator, and co-moderator since 2002. He served as a Chair-Elect on ASEE ECC Division in 2011. He also served as a program chair on ASEE ECCD in 2010. He is also serving on advisory boards of International Sustainable World Project Olympiad (isweep.org) and International Hydrogen

Energy Congress. Dr. Pecen received a certificate of appreciation from IEEE Power Electronics Society in recognition of valuable contributions to the Solar Splash as 2011 and 2012 Event Coordinator. Dr. Pecen was formerly a board member of Iowa Alliance for Wind Innovation and Novel Development ([www.iawind.org/board.php](http://www.iawind.org/board.php)) and also represented UNI at Iowa Wind Energy Association (IWEA). Dr. Pecen taught Building Operator Certificate (BOC) classes for the Midwest Energy Efficiency Alliance (MEEA) since 2007 at Iowa, Kansas, Michigan, Illinois, Minnesota, and Missouri as well as the SPEER in Texas and Oklahoma to promote energy efficiency in industrial and commercial environments.

Dr. Pecen was recognized by State of Iowa Senate on June 22, 2012 for his excellent service and contribution to state of Iowa for development of clean and renewable energy and promoting diversity and international education since 1998.

**Mr. Marc Casper, Association for Computing Machinery**

I am a current undergraduate Computer Science student at Sam Houston State University. Graduation date is expected to be May 2023.

**Austin Wayne Weirich**

# **Involving Multi-disciplinary Undergraduate Students in the Design and Development of an Innovative Device for the Detection of Plant Nematodes**

## **ABSTRACT**

This work-in-progress paper presents the contributions of a group of multi-disciplinary undergraduate students in the different phases of designing and developing an innovative device for the non-destructive rapid detection of plant nematodes (PN). Working as a team, undergraduate students majoring in mechanical engineering technology (MET), electronics and computer engineering technology (ECET), and computer science (CS) have been working on the mechanical design and prototype development, electronics and control, and software design and development components of the project supported by the US Department of Agriculture (USDA) since 2020.

PNs are parasites that attack plants through their roots and can negatively affect many crops of agricultural importance. Once established, PNs can be widely dispersed by several factors, including machinery, handheld planting equipment, movement via shoes and clothing, movement of soil, and many other mechanisms as their eggs live and hatch in the soil. Since juvenile nematodes penetrate the host plant roots to develop into adult females with eggs presenting as a cyst attached to the plant roots, it is possible to detect the morphological differences between healthy and infected plants by examining their roots. A minirhizotron with a camera module mounted on a precise linear motion system driven by a stepper motor and controlled by a microcontroller is developed to image plant roots. By applying custom-designed image processing algorithms, suspected areas representing cysts of PNs can be identified.

This paper shows the design, prototype development, and experimental tests of the first model that integrates the minirhizotron probe, the microcontroller, and a touchscreen with a graphic user interface (GUI), the second design that separates the minirhizotron probe and a hand-held controller with a GUI and cables for communications between the two parts, and the ongoing wireless network capable minirhizotron probe that can be accessed via a web-browser based GUI.

## **INTRODUCTION**

PNs have become significant pests that can negatively affect numerous agriculturally important crops. Their penetration of host tissues via mostly root systems can lead to the disruption of water and nutrition uptake and flow, resulting in underdeveloped plants and significant agricultural losses. In addition, they can be problematic within the nursery industry since the industry needs to continuously obtain maximum seedling and plant production, often with the same or similar stock plants and in close proximity to one another. The nursery environment provides ideal conditions for the reproduction and dispersal of nematodes' cysts and adult females. Once nematodes become established in a nursery setting, sold for planting, and

established in the ground, these PN can become widely dispersed by a number of factors, including machinery, handheld planting equipment, the movement via shoes and clothing, the movement of soil, and many other mechanisms. Timely inspection and detection are critical to the control of these PNs.

PN diagnostics are difficult via visual inspection by host plant symptoms, and molecular/laboratory diagnostics are typically time-consuming and costly. Visual inspection of plant roots may destroy healthy plants and plant tissue. The need to develop new innovative ways and equipment to detect cyst nematodes is crucial. This paper presents an in-progress project to develop an innovative portable minirhizotron-based device and method for rapid in-situ nondestructive inspection and detection of PNs. A group of multidisciplinary undergraduate students has been involved in developing the device, including researching, designing, prototyping, and testing all hardware and software.

## **METHODS**

Female PNs normally attack host plants by penetrating their root systems to absorb nutrition for reproduction. In this process, abnormalities such as a cyst full of PN eggs will develop and attach to the host plants' root systems before being released to the surrounding soils for hatching. The key to the success of the proposed device relies on the detection of morphological differences between healthy and PN-infected host plants' root systems. The team proposed a portable probe that can be positioned in the vicinity of the host plants' root systems to capture the image of the host plants' root structure and abnormalities due to PN infection if there are any. The ultimate goal is to visibly and quickly identify the differences between healthy and PN-infected host plants' root systems while, at the same time, differentiating normal surrounding soil. Moreover, by developing and applying image analysis algorithms to analyze the obtained images, the existence or absence of the PNs can be determined.

Based on a preliminary literature review, the team pursued a design for the proposed device similar to the minirhizotron, which utilizes transparent underground structure for solid and plants root study. The device consists of a motorized mechanical system that controls a modular camera traveling along a previously buried clear tube to take images of the suspected plants' root systems for further analysis. The device integrates mechanical motion control, digital imaging, and image analysis components into a portable handheld device for on-site rapid detection of PNs. The team followed the product design processes to build the prototype, including concept design, specifications development, alternative designs, analysis, prototype construction, experimental tests, and optimization to finalize product. The design and development of the proposed device involve three major components requiring multi-disciplinary collaboration:

1. **Mechanical Design and Prototype Development:** design and prototype the integrated device to include all the mechanical mechanisms, battery, camera module, controllers, and other related components.

2. Control System: design and prototype a control system, including both hardware and software, to drive the mechanical mechanisms, take images, and interact with users.
3. Image Analysis: develop image processing algorithms for analyzing and identifying possible PNs on the images taken by the probe.

## CONCEPTUAL DESIGN

Based on a review of minirhizotron devices and their applications in studies of plant root systems, the team developed a two-module conceptual design: a handheld portable controller in which controllers, battery, data storage, graphic user interface (GUI), and a touch screen for user interface are housed, and a minirhizotron style probe in which a digital camera module, stepper motor for precise motion, and LED lights for illumination are integrated. The probe is placed partially into the soil surrounding plants to be inspected, allowing the digital camera to take images of the plant root system while traveling along the probe. The two modules will communicate via a set of detachable cables. *Figure 1* shows the conceptual design of the proposed portable device.

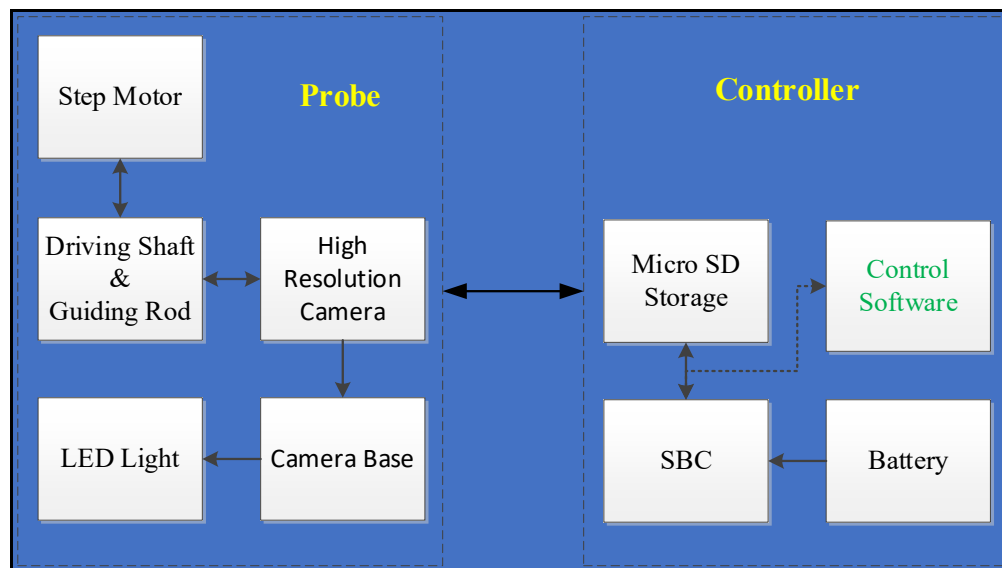

*Figure 1: Function block diagram of the proposed device*

## PROTOTYPE DESIGN AND DEVELOPMENT

### *Fully Integrated Design*

The initial approach is an integrated design in which both the probe and controller are assembled into one portable device. The unit integrates a Raspberry Pi 4B (Pi) single-board computer (SBC) as the central controller, an Iverntech NEMA 17 stepper motor with a minimum of 1.8° step angle integrated with 310mm T8 lead screw shaft to move an eight-megapixel Arduicam camera module with autofocus capability mounted on the lead screw, a five inches touchscreen for the GUI user interface, a Geekworm stepper motor controller, and a LED light for

illumination. *Figure 2* shows the CAD models of the interior and fully assembled device, and *Figure 3* shows the fully assembled prototype.

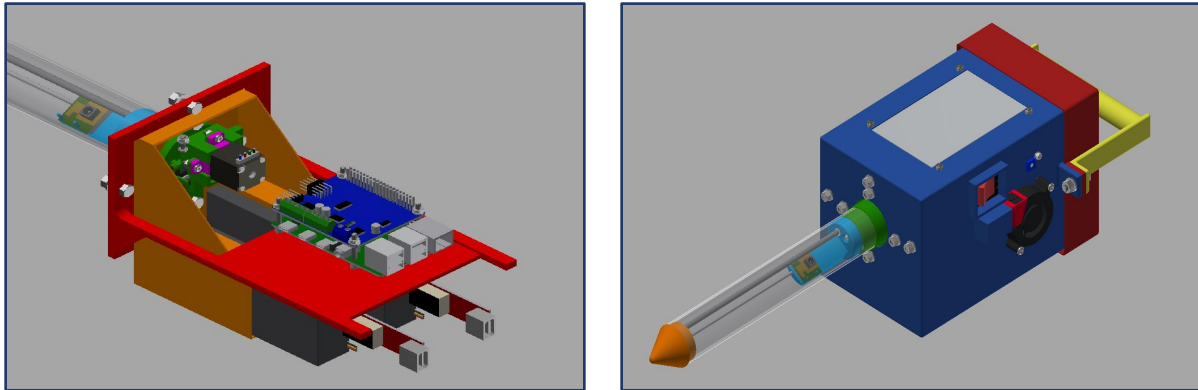

*Figure 2: CAD models of the interior and fully assembled integrated design*

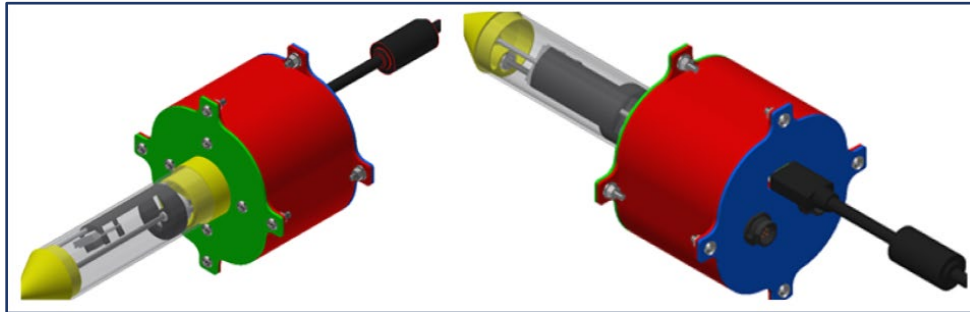

*Figure 3: Fully integrated prototype*

### ***Two-Module Design***

In the initial experimental tests using the fully integrated all-in-one prototype, although it successfully took images of the plant's root systems, it was observed that the system was top-heavy when the probe was inserted into the soil. The touch screen is also located at the ground level requiring the operator to lower down in order to operate the unit. The fully integrated design also makes assembling, maintaining, and repairing the device challenging. Therefore, a

two-module design to separate the probe and the controller was proposed. The controller integrates the 5" touchscreen, the Pi 4B SBC, the stepper motor controller, and batteries, while the probe consists of the stepper motor, the camera module, and the LED light. The two modules will communicate via three detachable cables for the camera signal, stepper motor control, and power supply to the probe. *Figure 4* and *Figure 5* depict the CAD models of the fully assembled probe and controller. *Figure 6* shows prototypes of the two-module design probe compared to the fully integrated design, and the controller prototype.



*Figure 4: CAD model of the probe*

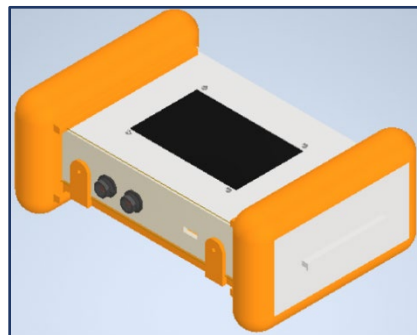

*Figure 5: CAD model of the fully assembled controller*

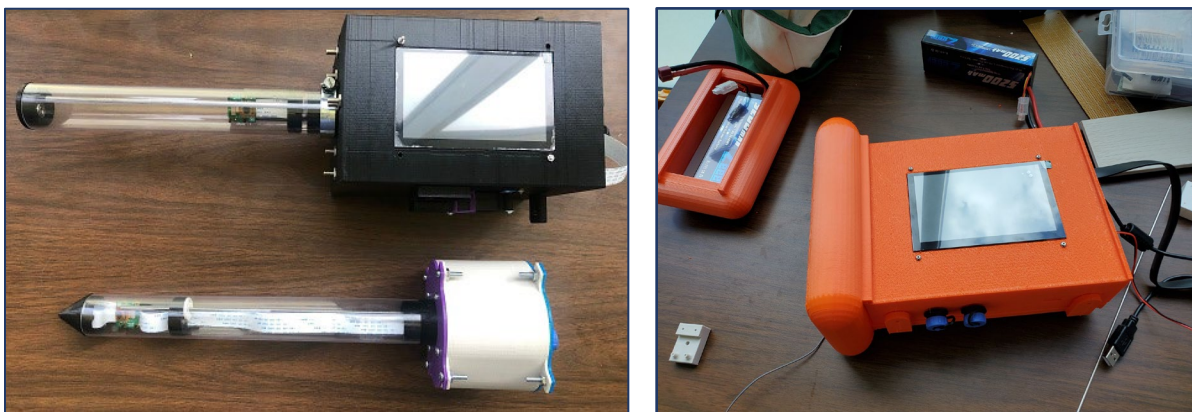

*Figure 6: Controller and probe prototype compared with the all-in-one prototype*

## **CONTROL SYSTEM**

The control system functions as the 'brain' of the device coordinating all the proposed functions

of the device. The Pi SBC was chosen for this project because of its processing power and the availability of third-party products for expansion. The Pi 8GB RAM model was used to ensure an efficient execution of all control and image processing algorithms required for both image-taking and post-processing. The Pi was also equipped with a 32GB microSD card for both the Raspbian OS for Pi and storage of the image files. the Pi to work independently without a laptop or computer system in the field, the controller code has been set up without either keyboard or controller. Only a Pi itself is needed to operate the entire system. After having the two modules connected and then turning on the power switch on the controller, the system automatically enters the GUI waiting for user interactions. The GUI allows an operator to perform functions such as adjusting the camera to focus, setting the starting position of the camera, running the image-taking procedure, and saving and transferring image files. *Figure 7* shows the schematic design and control flow of the device.

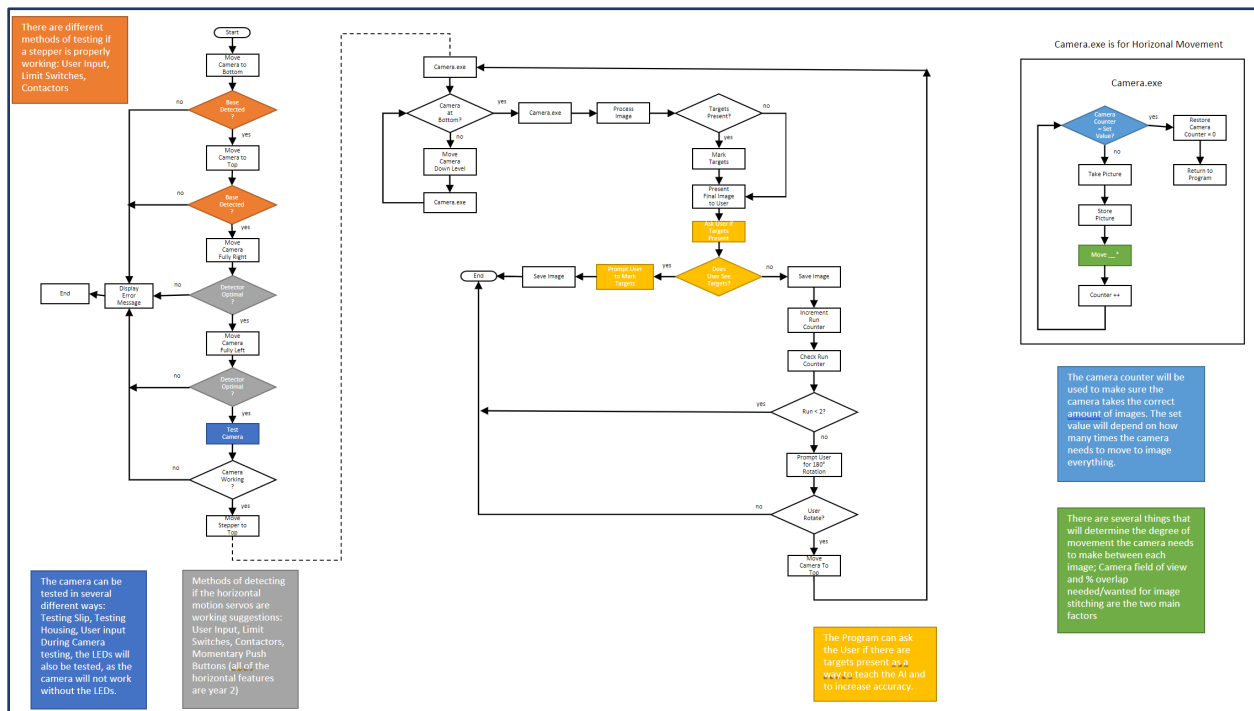

Figure 7: Function blocks and logic flow of the control system

## GRAPHICAL USER INTERFACE

A simple GUI working with touchscreen to perform all system functions is developed. It allows users to perform all tasks via button clicks with a few customized controls and adjustments, such as setting the camera focus and position manually. *Figure 8* shows a sample sub menu to setup the camera.

At the start of the program, the GUI initializes the camera's position by moving it to the top of the probe. A user can then start the automatic image-taking process via the GUI. Once the process begins, the stepper motor will drive the camera down the probe as it takes photos of plants' root systems surrounding the probe. When the camera reaches the bottom of the probe,



the camera will be returned to the initial top position completing the image-taking process. The image processing algorithms can then be applied to analyze the images and highlight areas identified as potential PNs. The results obtained from this process can also be exported to a USB flash drive for further study.

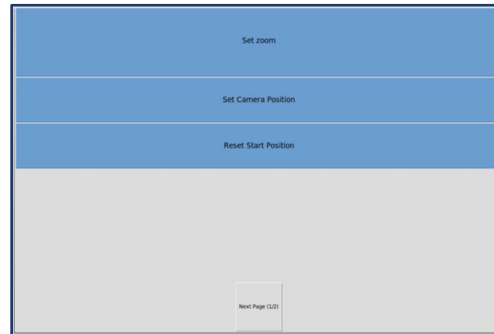

*Figure 8: Sample camera setting GUI*

## **IMAGE PROCESSING**

A plant may have a PN infection when bright spherical galls are present along with its root system. The images taken by the camera are stitched together to form a unifying panoramic. Subsequently, the panoramic image is converted from the RGB to the HSV color space to select saturation and value above a specified threshold to isolate regions in the color range representing the targeted galls. An additional pass is performed to remove segments of the image that conform to a line representing plant roots and subsequently filter them out. At the end of this process, a collection of bright round shapes that are suspected PNs satisfies positive detection criteria. If positive detection occurs, the masks are edge detected, expanded, and overlaid onto the image for further review.

## **EXPERIMENTAL TESTS**

The team conducted a series of experimental tests using both the healthy and nematode-infected tomato plants in a laboratory environment. *Figure 9* shows prototypes of both the all-in-one and probe-controller two-module designs being tested using both health and PN-infected tomato plants. *Figure 10* and *Figure 11* show example images of healthy and nematode-infected tomato plants' root systems, respectively.

By applying the image processing algorithm to convert the image from RGB to HSV color space, identify the ranges of HSV value for the targeted objects on the images, and generate a mask to overlay on the images, suspected PN-infection areas will be highlighted. *Figure 12* shows the raw (left), in the process of being processed (two in the middle) and processed (right) images with the suspected PN-infected gall highlighted.

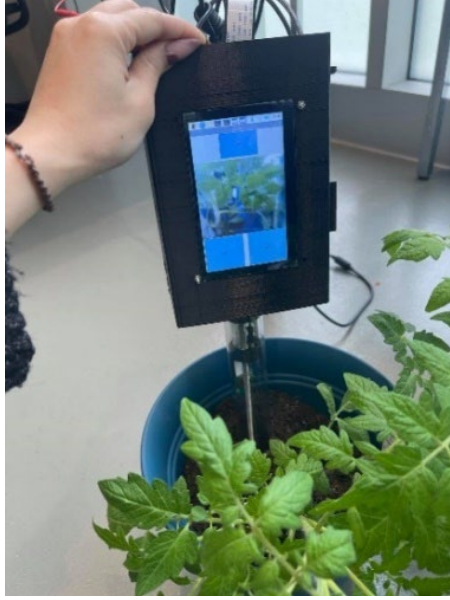

*Figure 9: Experimental testing of the all-in-one and two modules design prototypes*

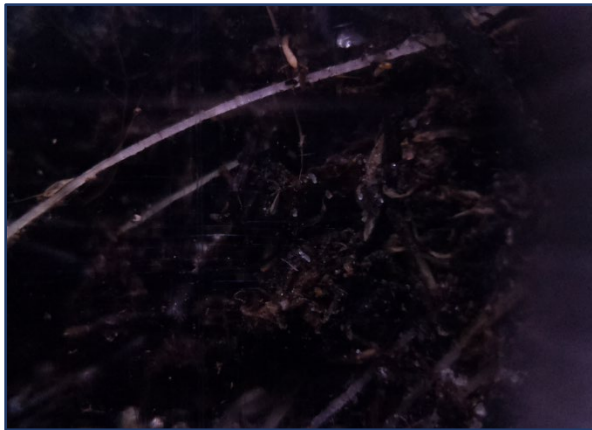

*Figure 10: Root systems of healthy tomato plants*



*Figure 11: Root systems of PN-infected tomato plants*

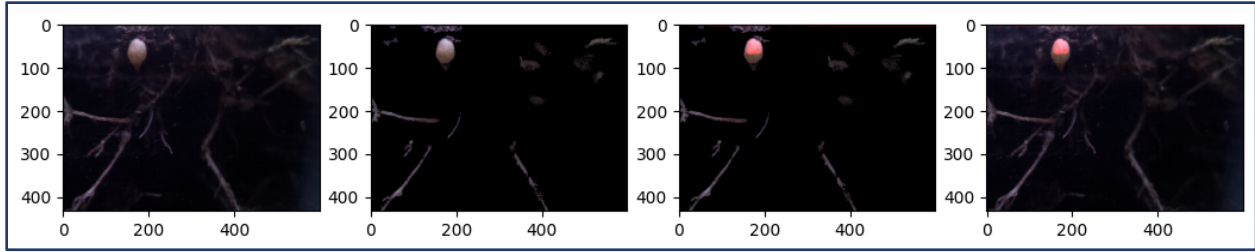

*Figure 12: Results of the new algorithms for cyst identification applied to a plant in the lab*

## **CONCLUSIONS AND FUTURE WORK**

By involving a group of more than 12 undergraduate students with majors in Mechanical Engineering Technology (MET), Electronics and Computer Engineering Technology (ECET), and Computer Science (CS) since June 2020, the team successfully developed the

The team including faculty advisors representing three academic units on campus and three undergraduate students with the afore-mentioned three majors are currently working on improving the system to equip the probe with a self-sustained power source and network capability suitable for extended field deployment. A web browser-based GUI is also being developed, allowing remote access to the system with appropriate authorization. By incorporating machine learning (ML) into the image processing algorithms, the ultimate goal is to be able to identify the species of the PN infecting plants inspected.

## **ACKNOWLEDGEMENT**

The team thanks the generous support of the US Department of Agriculture (USDA), Plant Protection Act (PPA) Section 7721 for the three FY2020, FY2021, and FY2022 years.

## References

Svane, S. F., Dam, E. B., Carstensen, J. M., & Thorup-Kristensen, K. (2019). A multispectral camera system for automated minirhizotron image analysis. *Plant and Soil*, 441(1-2), 657-672.

Rahman, G., Sohag, H., Chowdhury, R., Wahid, K. A., Dinh, A., Arcand, M., & Vail, S. (2020). SoilCam: A Fully Automated Minirhizotron using Multispectral Imaging for Root Activity Monitoring. *Sensors*, 20(3), 787.

"Management of soybean cyst nematode." Morning AgClips,  
<https://www.morningagclips.com/management-of-soybean-cyst-nematode/>

"Image Segmentation Using Color Space in OpenCV + Python." *Image Segmentation Using Color Space in OpenCV + Python - Programmer Sought*,  
[www.programmingsought.com/article/24214454012/](http://www.programmingsought.com/article/24214454012/).

Li, Xin, et al. "Visual Measurement Method of Image Stitching Based on Homography Matrix and Image Quality Evaluation: Semantic Scholar." *Undefined*, January 01, 1970,  
[www.semanticscholar.org/paper/Visual-Measurement-Method-of-Image-Stitching-Based-Li-Wu/a2d711772020106c6cb4adfd8d3988e68190ffaf?p2df](http://www.semanticscholar.org/paper/Visual-Measurement-Method-of-Image-Stitching-Based-Li-Wu/a2d711772020106c6cb4adfd8d3988e68190ffaf?p2df).

Maeght, Jean-Luc, et al. "How to Study Deep Roots—and Why It Matters." *Frontiers in Plant Science*, vol. 4, 2013, doi:10.3389/fpls.2013.00299.

Oliveira, Maria Do Rosário G., et al. "Auger Sampling, Ingrowth Cores and Pinboard Methods." *Root Methods*, 2000, pp. 175–210., doi:10.1007/978-3-662-04188-8\_6.

Pulkit Sharma. "Image Segmentation: Types Of Image Segmentation." *Analytics Vidhya*, October 19, 2020, [www.analyticsvidhya.com/blog/2019/04/introduction-image-segmentation-techniques-python/](http://www.analyticsvidhya.com/blog/2019/04/introduction-image-segmentation-techniques-python/).