

## **Gotta Catch 'Em All: Learning Graphical Communications through an Introductory Hands-on Design-Build-Test Project in a Hybrid Learning Environment**

### **Anna Wang, University of California San Diego**

Anna holds a MS in Structural Engineering from UC San Diego and a BS in Mechanical Engineering from Georgia Tech. She is currently working as an Associate Project Consultant in Simpson Gumpertz and Heger's Engineering Mechanics and Infrastructure group. Anna will continue her education at McGill University this fall for her PhD in Civil Engineering with a research focus on seismic assessment of historical masonry structures and engineering pedagogy.

### **Dr. Lelli Van Den Einde, University of California San Diego**

Van Den Einde is a Teaching Professor in Structural Engineering at UCSD. She incorporates education innovations into courses (Active Learning, Project-based learning), prepares next generation faculty through TA Training, serves as advisor to student organizations, and is committed to fostering a supportive environment for diverse students. Her research focuses on engagement strategies for large classrooms and developing K-16 design-based curriculum in earthquake engineering and spatial visualization to support persistence.

### **Dr. Nathan Delson, eGrove Education**

Nathan Delson, Ph.D. is a Senior Teaching Professor at the University of California at San Diego. He received a PhD in Mechanical Engineering from MIT and his interests include robotics, biomedical devices, product design, engineering education, and maker spaces. In 1999 he co-founded Coactive Drive Corporation (currently General Vibration), a company that provides force feedback solutions. In 2016 Nate co-founded eGrove Education an educational software company focused on teaching sketching and spatial visualization skills.

# **Gotta Catch ‘Em All: Learning Graphical Communications Through an Introductory Hands-on Design-Build-Test Project in a Hybrid Learning Environment**

## **Abstract**

The maker movement merges creative makers and advanced technologies such as the Arduino microcontroller and 3D printing to drive advances in manufacturing, engineering, industrial design, hardware technology and education. Design-build-test challenges not only provide opportunities for students to learn deeper through making, but also educate next generation engineers in practical concepts such as technical communication, teamwork, and design reviews. The incorporation of 3D printing and computer aided design (CAD) in these courses also allows students to encounter the realities of the manufacturing and design processes and promotes student engagement. These projects not only “provide an alternative assessment method for students who may not excel on written quizzes and exams”, but also teach students technical communication skills. While design-build-test projects are a common Design Based Learning (DBL) pedagogy technique in engineering education, the COVID-19 pandemic introduced challenges for hands-on engineering learning. The need to move to hybrid or completely remote learning environments resulted in students lacking the in-person makerspace experience which has been demonstrated to improve confidence in engineering design by demonstrating the realities of prototyping and manufacturing.

An 8-week design-build-test project called the Pokémon Challenge was implemented in the freshman Engineering Graphics course at the University of California, San Diego during Spring 2022 when classes were in person but many students had to quarantine due to COVID. The motivation of the Pokémon Challenge was to allow students to apply the engineering design process while developing prototyping and graphical communication skills through hand-sketching, CAD, and manufacturing techniques. This paper introduces the Pokémon design-build project and describes some of the implementation challenges faced during the pandemic related to teamwork, motivation, and the ability to ensure all students were able to participate even if remote. A survey was conducted at the end of the project to understand the students’ perspective on their learning outcomes and experience. Furthermore, a peer review of team dynamics was administered at both the midpoint and end of the project. The survey at the midpoint of the term project asked students to provide specific, constructive feedback on their peers so that teams could address their issues and improve their team dynamic prior to wrapping up the project. The peer review survey repeated at the end of the term included survey questions rating the degree to which teams had high levels of cooperation and mutual support, took initiative to resolve issues between themselves, and how much they appreciated one another's unique capabilities. This case study found that despite communication challenges and fluctuations with safe, in-person learning, a hybrid approach to design-build-test projects is

effective in meeting practical student learning objectives. The study showed that while in person DBL is ideal, a hybrid DBL contributes to easy access to learning while still enabling participation and creativity. Best practices for supporting a collaborative hybrid learning environment for CAD based projects are provided.

## **1. Introduction**

The maker movement combines creative makers and advanced technologies such as the Arduino microcontroller and personal 3D printing to drive innovation in manufacturing, engineering, industrial design, hardware technology and education [1]. Through the process of making, students learn deeper. 3D printing and rapid prototyping allows students to practice the iterative design process [2] to produce a functional, aesthetic, and viable product [3].

Hands-on projects provide students with a “real world” engineering experience that enhances learning over standard course work. They allow students to experience a design-build-test process with well-defined design goals and cost and time constraints. Students learn the importance of creating a schedule and meeting deadlines, communication and coordination, cost implications, manufacturing and tolerancing issues, and documenting their design process [4, 5]. Providing clearly defined rules and requirements are integral to the success of the project. Design competitions should provide performance targets but include flexibility in how the students can achieve the performance goals [4].

3D printing and computer aided design (CAD) can be used in design-build-test projects for introductory courses to enrich student experiences [5]. They provide a realistic opportunity to explore the nature of the engineering design process [6] and promote student engagement [7]. The inclusion of 3D printing allows students to see what works and what does not work, forcing them to make required design changes [7].

Design-build-test challenges also provide opportunities to educate next generation engineers in practical concepts such as design reviews, technical communication, and teamwork. Design reviews have been recently incorporated into design challenges because they are recognized as an important element in delivering a quality product for a customer [8, 9]. They provide a mechanism to determine if the design meets the customer’s specifications and fosters communication between the customer and student teams. Additionally, they improve the quality of the design through feedback from the customer and other technical experts. Design reviews can focus on technical aspects as well as testing of the product [9].

Technical communication skills can be incorporated by including a design presentation and/or report to ensure that students can communicate their design intent and understand the impact of their decisions in the design-build-test process [1]. Poster presentations are a form of technical communication that benefits students by allowing them to prepare exhibits (i.e., posters),

participate in a dynamic learning environment that simulates a technical conference and “provides an alternative assessment method for students who may not excel on written quizzes and exams” [10].

The design-build-test challenge environment is also effective in promoting academic motivation. Students feel more motivated to complete an assignment if it is relevant to their career goals, and the increased motivation is partially associated with higher engagement in learning and improved group and communication skills [11]. A design-build-test project allows students to work together towards a tangible outcome and develop the critical non-technical skills that are not explicitly taught in engineering curriculum [12].

The COVID-19 pandemic introduced challenges for hands-on engineering learning. While many courses experienced varying degrees of success with moving hybrid or completely remote, students experienced obstacles such as internet connectivity and finding quality learning spaces and technology [13]. CAD and other engineering software replaced the maker space as primary tools for design-build-test projects, and students had to focus more on developing simulation skills. Therefore, students during COVID were deprived of the in-person makerspace experience which has been shown to improve confidence in engineering design by demonstrating the realities of prototyping and manufacturing [14]. Remote students also reported feeling a lack of “relatedness”, a sense of belonging and value within a team. Opportunities to form relationships with their peers in hybrid or in-person courses can increase feelings of relatedness and lead to higher academic performance [15].

Given the sudden changes to the hands-on learning environment, a novel design-build-test project called the Pokémon Challenge was implemented in a freshman Engineering Graphics course at the University of California, San Diego. The primary learning objectives for the project were to develop spatial visualization and reasoning skills, understand the power and precision of computer-aided modeling, construct accurate complex 2D and 3D shapes, organize and deliver effective verbal, written and graphical communication, and apply relevant sketching, 2D and 3D techniques using modern engineering tools in a team-based setting to design parts of a larger system. The 8-week project started during week 4 of the 11-week quarter with the final competition and deliverables due during Finals Week in Week 11) and provided detailed performance specifications, required students to undergo design reviews and work in teams, and provided multiple opportunities for teams to communicate their design process. This paper introduces the design challenge and describes some of the implementation challenges faced during the pandemic related to teamwork, motivation, and the ability to ensure all students were able to participate even if remote. Based on student survey data, recommendations for improved implementation practices for future design-build-test projects are presented.

## **2. The Pokémon Challenge**

The previous, pre-pandemic design-build-test project for this course involved creating a rube goldberg machine with the longest run time [1] which had very similar deliverables and learning objectives to the Pokémon Challenge. However, once the pandemic hit and remote teaching was required, the course pivoted to a software only design project. When the opportunity to finally be in-person presented itself again, the teaching team decided to develop the Pokémon Challenge, which built on its predecessor project but also introduced concepts of optimization and streamlined the logistics of the project to make it more manageable to implement.

The purpose of the Pokémon Challenge was to allow students to use the engineering design process while building upon their prototyping and graphical communication skills through hand-sketching, CAD, and manufacturing techniques. The fictional project theme, which was selected to engage students, tasked them to develop a mechanism that would help Professor Oak catch all the Pokémon in the Kanto region to help him fill his Pokédex and further his research. Students were asked to optimize their Pokémon catching method and create a design that would be creative, aesthetically pleasing, fit within Prof. Oak's grant budget, and be able to catch the rarest Pokémon. Teams of 3-4 engineers were commissioned to develop a machine that could move a mass (the Pokéball) from the Start Zone to the End Zone. Each machine started from rest and was triggered by a pre-programmed Arduino and servo motor.

Teams competed individually as well as part of a conference (Valor, Mystic, or Instinct), each led by a Teaching Assistant. To incentivize students, the winning individual teams and the winning conference received extra credit on their final term project grade.

## 2.1 Competition Format

Fig. 1 shows the complete test set-up for the Pokémon Challenge. A crocheted hacky sack with a mass of approximately 41 g and a diameter of 2" was used as the "Pokéball" (Fig. 2).

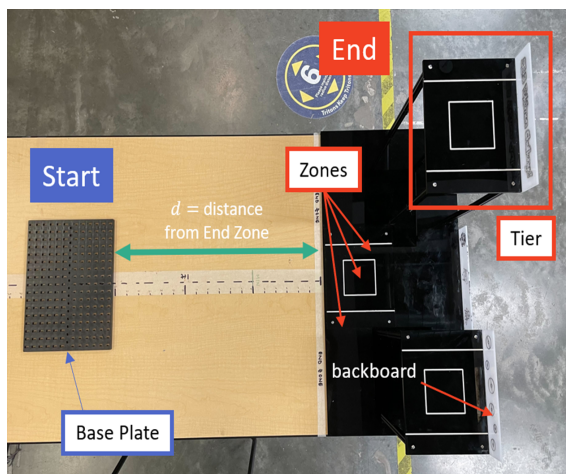


Fig. 1 Test Setup



Fig. 2 Pokéball

### 2.1.1 Start Zone

Each team received a Base Plate that acted as the foundation for their machine. Base Plates measured 10.1"x7.3", and had cutouts spaced at 0.59" apart for attaching Fischertechnik or custom parts.

### 2.1.2 End Zone

The End Zone consisted of three platforms (Tiers) at varying heights with each Tier separated into three Zones (Fig. 3a), like a target (Fig. 3b). Each Zone had a 2-inch-tall backboard. The Pokéball was permitted to bounce off the backboard, but teams would receive a penalty on their accuracy score for doing so.

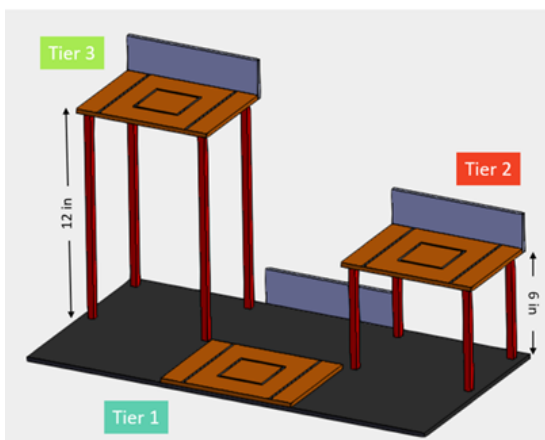


Fig. 3a End Zone

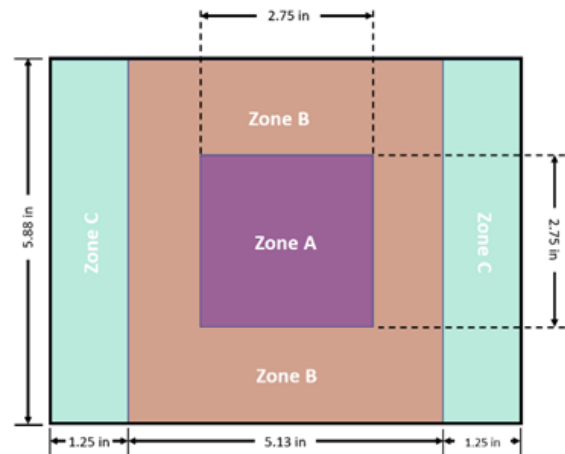
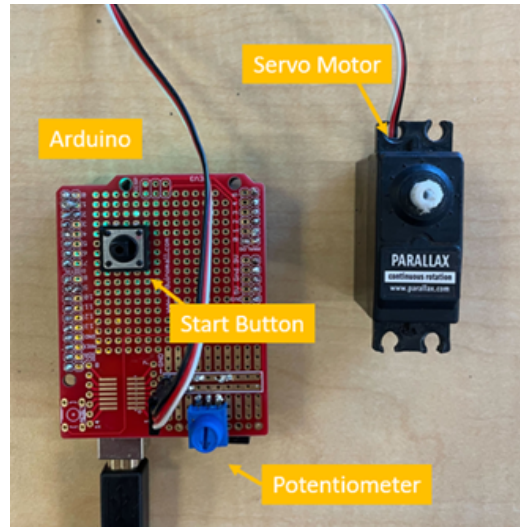


Fig. 3b Tier Close-up and Zone Numbering

### 2.1.3 Arduino & Servo Motor

Fig. 4 shows the given Arduino and servo motor controller used to trigger the machines. Teams could use a potentiometer to adjust the duration that the servo motor rotates (from 1 to 10 sec).



*Fig. 4 Arduino and servo motor set up*

## 2.2 Project Requirements

Each machine had to meet certain engineering requirements or risk being disqualified. The machine had initial dimensional constraints of 10.1”x7.3”x14” (i.e., the machine had to fit within the footprint of the Start Zone and be no more than 14” tall). However, there were no boundaries for the machine after being triggered. The Pokéball was not permitted to touch the floor at any time. The centerline of the base plate also had to be in the center of the test set-up and orthogonal to the edge of the End Zone. Therefore, aiming for the higher tiers required a custom connection to angle the mechanism relative to the base plate while still staying within the footprint of the Start Zone. The servo motor was also required to be within the Start Zone (so students had to design a mount or holder). However, the Arduino and wiring could remain outside. Machines were required to be at rest prior to using the Arduino to start the servo motor. Teams also had a 3-minute time limit to set-up their machine.

In addition, each machine was required to have at least one unique 3D printed part per team member, one unique laser cut acrylic part per team member, and one type of connection. A connection is described as any feature that joins two or more pieces together. At least one 3D printed part had to be larger than 1”x1”x1”. These requirements were set to ensure that every student had experience using both the 3D printer and laser cutter. All required parts had to actively contribute to the mechanism of the machine; however, one laser cut piece was allowed to be decorative.

Each team member was not only responsible for the CAD and fabrication of their required 3D printed and laser cut parts but was also responsible for a sub-assembly. Their individual required

parts may have been a component of a teammate's sub-assembly, requiring collaboration between team members during all stages of the design process.

Aside from the above constraints, the project was left very open-ended to allow for creative engineering solutions. While many teams opted for a simple, rubber-band powered catapult, other teams created scoping or scissor mechanisms, cannons, and trebuchets. Some teams incorporated mechanisms to easily adjust the angle and rotation of their launch. Since the instructions only identified the constraints and objectives of the project, students could experience the engineering design process from start to finish.

### 2.3 Performance Index

To quantify which machines were the most optimized, each machine was scored using a Performance Index (PI) which penalized cost and rewarded accuracy, height, and distance from the End Zone (equations 1-3). Accuracy was weighted the most followed by height and distance, respectively. Machines were also tested over three rounds for precision to ensure that teams did not get "lucky" during testing. Teams with a unique design or those that exceeded expectations in creativity and aesthetics were also awarded a bonus factor. The highest PI possible was 110. If a team did not land in a Zone/Tier (ex: landing on the base of the End Zone or the floor), the "Catch Rate" for that round was zero.

$$PI = \left(1 + \frac{A}{100}\right) \left(\frac{1}{k} \sum_{n=1}^k R_n + .015C\right) \quad (1)$$

where,

$A$  = aesthetic, creativity, and design score (0-10)

$k$  = number of rounds = 3

$$R_n = 3T_n + 5Z_n + 2D_n = \text{Catch Rate for round } n \quad (2)$$

$T_n$  = Height (tier) score for round  $n$  (0-10)

$Z_n$  = Accuracy (zone) score for round  $n$  (0-10), included a 50% penalty for hitting the backboard

$$D_n = (10pts) \frac{d-6''}{42''} = \text{Distance score for round } n \quad (3)$$

$d$  = distance from the front edge of the start zone to end zone in inches (min of 6" and max of 48")

$C$  = Cost in Pokédollars



## 2.4 *Materials*

Teams were provided with rental and consumable materials and a budget of 1500 “Pokédollars”. No other materials were permitted including adhesives such as glue or tape. This was to ensure that students would work on tolerancing to connect their pieces during the manufacturing process.

Rental materials included Fischertechnik parts, various sizes of rubber bands, and stainless-steel balls which could be used as weights. Rubber bands and stainless-steel balls were priced higher than other materials due to their potential energy. Therefore, teams who relied more on gravity and the servo motor as energy sources would incur a lower cost.

Consumable materials included a generous allocation of acrylic (12”x24” sheet at a random thickness) and 3D printing funds (40 hours per team). Additional acrylic and 3D printing funds could be purchased at a low cost. This was to encourage teams to develop more custom parts rather than relying on the more expensive rental pieces. Spectra fiber (a specialty fishing line used for pulley applications), one 18” aluminum rod, and #4-40 screws, nuts, and washers were also provided at no cost with no limitations.

## 2.5 *Deliverables*

Throughout the 8-week term project, the students had to meet several deliverables and milestones to help pace them. In addition to lectures, two, 2-hour lab sessions were held weekly to provide students opportunities to work on their deliverables or present their progress to the instructor team.

### 2.5.1 *Team Design Reviews*

One lab session each week was dedicated to Team Design Reviews. Each two-hour lab had two instructors, who were responsible for meeting with 6-7 teams weekly. Prior to each Team Design Review, teams were required to submit an entry in their “Engineering Notebook” (a slide deck documenting their engineering design process). Teams would present their Engineering Notebook slides to the teaching team, similar to how they would present project updates to a client. This was not only for the students to document their engineering design process, but also for them to practice verbal and visual communication skills and get feedback from the teaching team. During each Design Review, teams were evaluated on teamwork, effective communication, and meeting the project requirements. Although a general timeline of the project was provided for the entire class, instructors also guided teams in creating customized interim milestones, including delegating responsibilities and breaking down steps to achieve their goals.

A conference design review was held halfway through the project to replicate a “peer review” and encourage collaboration and idea sharing between teams in the same conference (lab section). Each team presented their cumulative Engineering Notebook slides to their peers and provided constructive feedback to each other.

### 2.5.2 Sketching and CAD

All students started with individual hand-sketching and brainstorming prior to sharing their ideas with their teammates (Fig. 5). Teams were also required to designate roles such as Project Manager, CAD Manager, Manufacturing Lead, and Drawings Coordinator to ensure that all students held leadership responsibilities in at least one aspect of the project. They were also required to create a detailed schedule of their project plan and modify it weekly as needed to adjust for unforeseen circumstances.

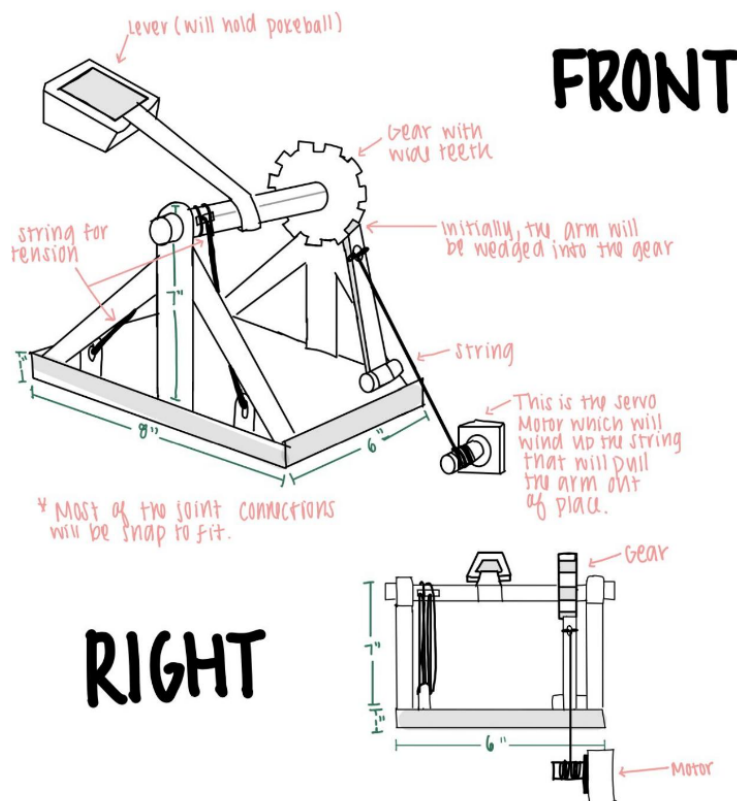
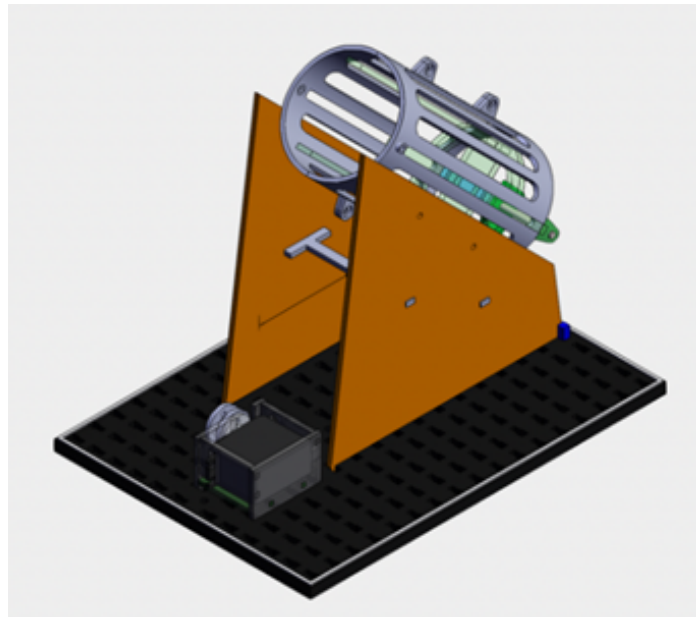


Fig. 5 Sample Conceptual Sketches

After deciding on an initial design, teams started to develop a SolidWorks assembly of their machine. A completed CAD model, including all parts, fasteners, and the servo motor, was required by the fourth week of the project (Fig. 6) prior to manufacturing for students to identify issues with connections and dimensioning. Students were introduced to hand-sketching,

SolidWorks, and AutoCAD in parallel with these stages of the project and were able to develop their skills through these practical objectives.



*Fig. 6 Sample CAD Model*

### *2.5.3 Manufacturing and Testing*

During the fifth week of the project, all teams demonstrated their prototypes in the first round of testing. Teams were permitted to manually deploy their machine or only demonstrate the working sub-assemblies. Only 9 teams (out of 46) had a complete mechanism that was able to be triggered using the motor during this stage. Students had a huge wakeup call about the importance of tolerancing as many parts did not fit together as expected. A week later, teams demonstrated their improved prototypes during testing round two. This round of testing served as a dry run of the final competition, and 38 teams had a working mechanism with the motor, showing significant improvement in just one week. The remaining two weeks were dedicated to iterating their design and completing the drafts of their drawing sets.

### *2.5.4 Drawing Sets*

In addition to a physical prototype, students were required to submit a complete engineering drawing set at the end of the quarter to demonstrate their graphical communication skills (Fig. 7). All drawings were required to be compiled on sheet size A using ANSI standards, and title blocks, fonts, leaders, sheet numbering. They had to be consistent across all sheets and between software programs (SolidWorks and AutoCAD).

Drawing sets were composed of a Title Page, General Notes Sheet, Bill of Materials, Build Schematic, Exploded Views of sub-assemblies and full assembly, sub-assembly placements, and custom part drawings completed in SolidWorks. Teams also included creative experimental test setup plan and elevation views drawn in AutoCAD using imported, traced, and hand-drawn blocks. Drawings were required to be detailed enough so that their parts could be replicated exactly. Therefore, students needed to include dimensions, detail callouts, and section views where necessary.

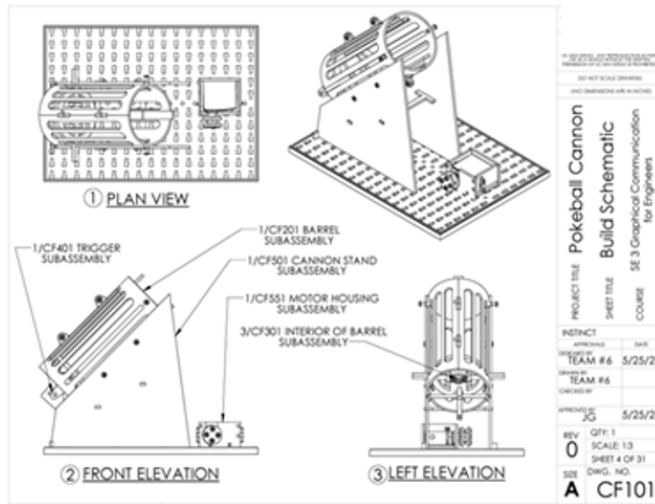


Fig. 7a Sample SolidWorks Drawings

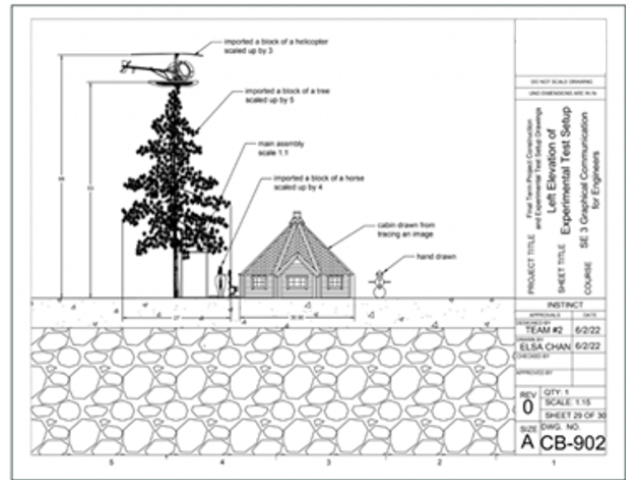


Fig. 7b Sample AutoCAD Test Setup

### 2.5.5 Final Competition and Poster Fair

The term project culminated in a final competition during the course's final exam block (Fig. 8). Teams presented their technical posters as well as demonstrated their final prototypes. Technical posters included SolidWorks model and drawing images, AutoCAD experimental setup images, a project overview, and the design approach. Teams highlighted key design features as well as challenges and learning points.

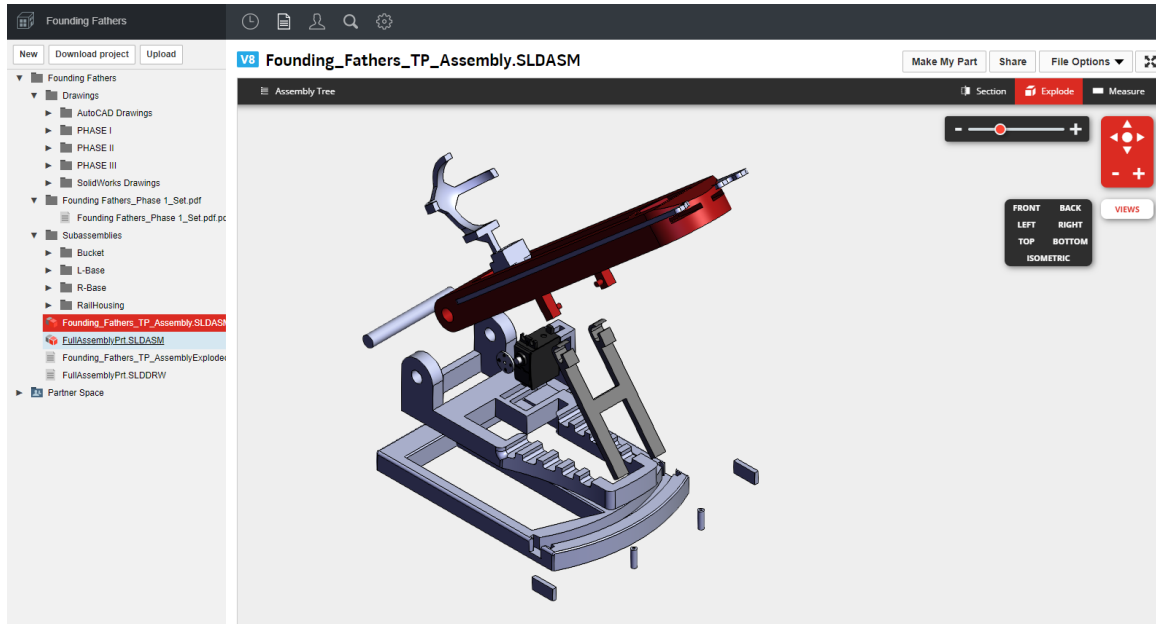


*Fig. 8 Final Competition and Poster Fair*

## *2.6 COVID Accommodations*

One of the biggest challenges for engineering education during the era of COVID is the implementation of hands-on activities. While CAD and hand-sketching are critical skills in the engineering toolbox and can be taught remotely, the in-person makerspace experience cannot be replaced virtually. Following university guidelines, this course was implemented in a synchronous, hybrid setting, with students participating in-person and remotely.

During the 2021-2022 academic year, UC San Diego courses were permitted to be up to 50% remote with masks required in all in-person classroom environments. To preserve the in-person makerspace experience as much as possible, students were required to attend all labs and lectures in-person; however, accommodations were made for those who were ill or had to quarantine by allowing them to attend synchronously via Zoom for Team Design Reviews and testing. Although these students were unable to actively participate in the makerspace, teams were still able to use special tools to continue making progress on their projects. For example, students used GrabCAD to share updated CAD files (Fig. 9), updated their Engineering Notebooks through Google Docs/Slides, and observed some of the laser cutting and 3D printing test runs that their teammates started through Zoom. This allowed students to not only participate in the full design and manufacturing process, but also work on flexible communication and collaboration skills, which are valued by employers, especially as industry becomes more globally connected.



*Fig. 9 Screenshot of GrabCAD subassembly*

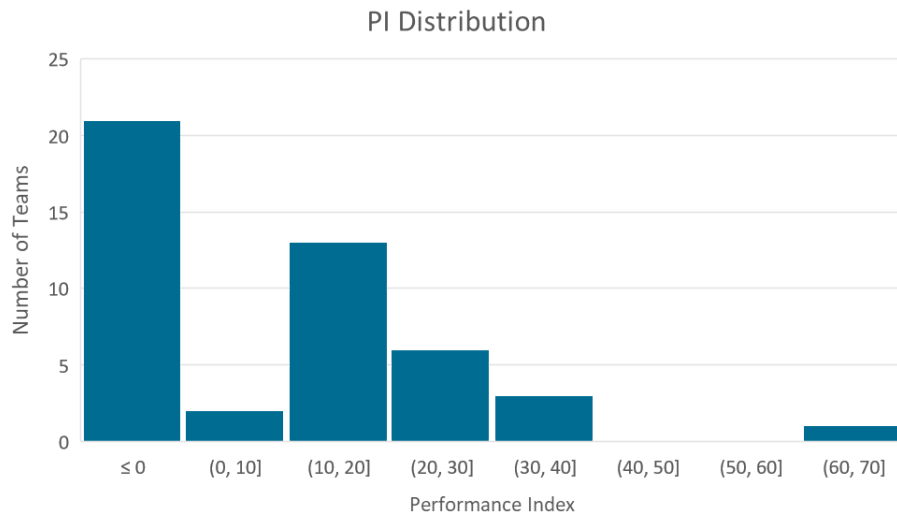
Providing this hybrid mixed-location learning environment still includes original challenges faced during purely remote learning such as engagement, and equity. But it also introduces new challenges, especially for the instructor to be able to manage the infrastructure to support in person instruction while simultaneously having some students join remotely. Managing a class like this results in increased operational complexity, and switching from remote to in-person instruction models simultaneously.

### **3. Project Results & Assessment**

During the final exam block, teams had 15 min to set-up and run their prototype over three rounds. When not competing, students were required to stand in front of their posters to present their project to their instructors and guests as well as check out posters made by their peers. Teaching Assistants helped with running the testing stations as well as grading the poster presentations.

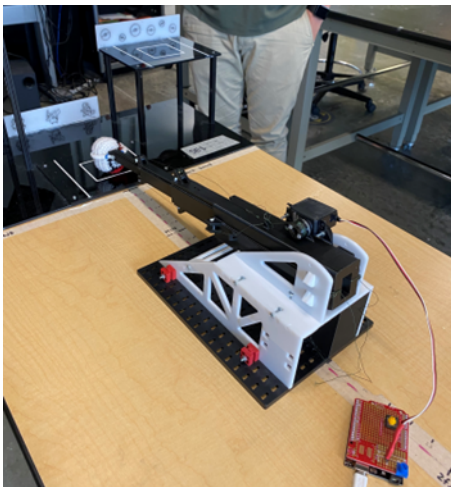
#### *3.1 Competition Results*

The class distribution of the PI's from the final competition are shown in Fig. 10.

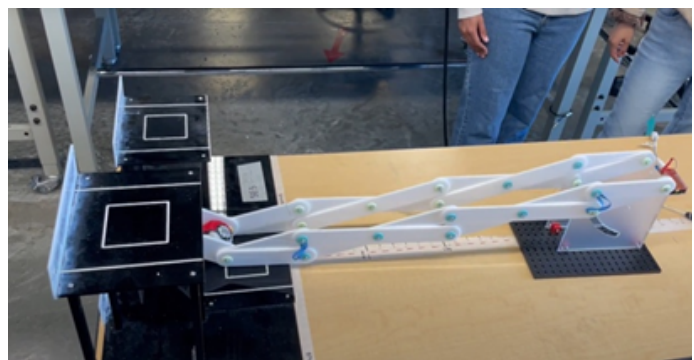


*Fig. 10 PI Distribution (46 total teams, maximum possible PI of 110)*

The winning team achieved a PI of 62, well above the class average of 11.1. Second and third place earned 35.9 and 35.1, respectively. 21 out of the 46 teams earned a PI of 0. The top two teams both had an extendable scoping or scissor mechanism, used mostly custom-made parts, and obtained consistent scores throughout all three rounds (Fig. 11). Although both teams did not reach the higher tiers, the PI rewarded them for their precision and accuracy, a consequence of their complex designs.



*Fig. 11a First Place*



*Fig. 11b Second Place*

Many teams were also successful using a launching mechanism (Fig. 12), which was easier to construct, but not as precise. These teams were successful in reaching the higher Tiers. However, they were less consistent and had a higher cost due to the use of rubber bands and stainless-steel balls.



*Fig. 12 Example Trebuchet*

### 3.2 *Survey Results*

The teaching team conducted a survey at the end of the term project to understand the students' perspective on their learning outcomes and experience. A Qualtrics survey was sent out at the end of the quarter to evaluate the course as a whole; however, only the questions focused on the term project are summarized below. 156 of the 176 students completed the survey.

Out of these 156 students, 97% of students agreed that the term project was helpful in applying course content. Furthermore, 95% agreed that the term project was effective in teaching them rapid prototyping and 86% agreed that the engineering notebook was an effective way to document their project status.

When asked what part of the term project they enjoyed the most, 42% of students said they enjoyed rapid prototyping using the laser cutters and 3D printers. Many students also expressed that they enjoyed seeing their CAD models come to life. One student commented "What I enjoyed most was making the prototypes and testing them because it gave us all a sense of how life as an engineer could possibly be". 82% of students also indicated that they enjoyed working in teams, including one student who commented "I enjoyed spending time with my groupmates and building friendships with them" and another who responded "I enjoyed the opportunity to work with others during the term project. Having different roles and dividing work to complete the project makes us feel proud of what we created". Students also acknowledged the benefits of the open-ended nature of the project, "I liked the creativity aspect of being able to take unique approaches to solve the given problems".



Students also expressed challenges and concerns about the project. Only 61% of students agreed that the amount of individual work for the project was reasonable. However, 81% of students agreed that the level of difficulty of the design-build-test project was reasonable. Many students mentioned that the workload was too high, with one commenting “I think it was too heavy on the work as it was taking over all of my other classes”. Others expressed that it was difficult to find an available 3D printer or laser cutter, especially during peak hours and prior to a deadline. The Maker Studio’s only large laser cutter was also down for maintenance during the final week of the project. Students also criticized the clarity of the term project directions and felt that the amount of information given was overwhelming.

### *3.2.1 Impact of Hybrid Learning*

This case study found that despite communication challenges and fluctuations with safe, in-person learning, a hybrid approach to design-build-test projects is still effective in meeting these practical learning objectives. However, this is a single iteration of a DBP with a specific set of course evaluations, and further studies will need to be conducted to draw widespread generalizations about hybrid learning in makerspaces.

From the student surveys, 80% agreed that the hybrid, synchronous delivery of the term project (with some students sometimes on zoom) did NOT impact them in successfully getting work done. The entire class was also virtual for one week during the CAD stage of the project due to a sudden increase in COVID cases. The most common benefits students highlighted for remote participation included flexibility and convenience of being able to attend remotely (15%), not having to physically go to the university or walk to the lab (12.6%), and health reasons such as COVID prevention (10.6%).

Approximately 30% of students did not provide comments about challenges or benefits of doing lab remotely because they did all their work in person. Additional results from the survey regarding the hybrid learning experience are summarized below:

- 76.3% of respondents interacted with a TA during the course
- 84% of respondents said the course was organized in a way that helped them learn.
- 85.8% of respondents said they had opportunities to interact with the instructor throughout the course.
- 90% of respondents said they had opportunities to interact with their classmates throughout the course.
- 89.6% of respondents said they would prefer that labs were in person.

The challenges students faced with remote participation were mostly what would be expected: Difficulty in collaborating and communicating with their peers and the teaching team (23%),

lack of engagement or interaction (19%), and the inability to participate in hands-on aspects of the class that students find more engaging and better for their learning (10%).

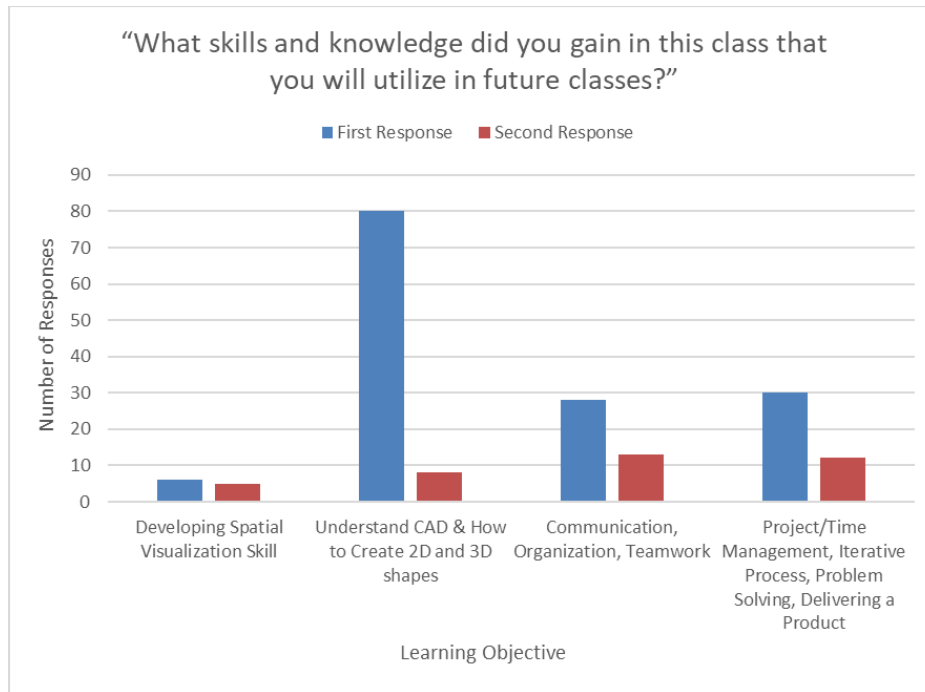
This project will be implemented again in the Spring 2023 quarter following the University's updated COVID guidelines: masking is now optional in indoor classrooms (except for those who have recently left isolation, are symptomatic but test negative for COVID, or have been exposed to COVID). Quarantining is only required for those who are symptomatic and waiting on test results or those with a confirmed positive result. Given these changes, the instruction team is able to implement this project in a fully in-person capacity. New survey results will be compared with last year's implementation to evaluate the effectiveness of the synchronous, hybrid learning experience in the makerspace.

### *3.2.2 Achieving Learning Objectives*

The free responses from the survey question "What skills and knowledge did you gain in this class that you will utilize in future classes?" were coded based on the following buckets that aligned with the five learning objectives for the course (Fig. 13):

1. Develop spatial visualization and reasoning skills
2. Understand the power and precision of computer-aided modeling,
3. Construct accurate complex 2D and 3D shapes,
4. Organize and deliver effective verbal, written and graphical communication,
5. Apply relevant sketching, 2D and 3D techniques using modern engineering tools in a team-based setting to design parts of a larger system.

Some students mentioned several skills they learned over the duration of the course. 56% of the responses indicated that the main takeaways for the course were learning CAD software (Learning Objectives 2 and 3). The next two highest responses were related to Learning Objectives 5 and 4, respectively. 21% of students indicated the main skills they learned related to Project or Time management, Iterative design process, problem solving and delivering/manufacturing a product (Objective 5), and 19% of the students said communication, organization and teamwork skills (Objective 4). Although not the primary objective stated, spatial skills (Objective 1) did receive responses (4%) as an initial response and 13% for those that listed multiple skills. Therefore, based on the reported self-efficacy by the students, all five of the learning objectives were met in this course.



*Fig. 13 Summary of student responses for top two learning objectives met*

### 3.2.3 Assessing Teamwork

The instruction team surveyed the students at the midpoint of the term project and asked them to provide specific, constructive feedback from their peers. This anonymous feedback was sent to each group so that teams could address their issues and improve their team dynamic prior to wrapping up the project. One student told their teammates “I think we had a few setbacks with our design... but I appreciate the flexibility that you guys have had in quickly changing designs. ... Achieving our deadlines is the only way that we'll be able to effectively complete this project so let's work together and support each other in the last few weeks of this project's culmination”.

Students filled out the same team evaluation at the end of the term project, which instructors used to adjust final term project grades as needed, depending on contributions from each member. Survey questions included rating the degree to which their team had high levels of cooperation and mutual support, took initiative to resolve issues between themselves, and how much they appreciated one another's unique capabilities. In addition, 87% of students agreed that team problem solving resulted in effective solutions, and 81% agreed that communication in their group was open and honest. These surveys were important not only for instructors to identify red flags early on, but also for students to communicate constructive feedback to their peers and for resolving internal conflicts professionally.

### 3.3 *Future Implementations*

Developing a design-build-project that meets desired learning objectives while recognizing the varying skills and knowledge that students bring to the table is challenging. A balance must be found between providing enough details about the project without over constraining students from being creative. The workload must be appropriate, and all deliverables must meet the learning objectives. Furthermore, implementing a maker hands-on project during a pandemic presents additional complications with supporting rapid prototyping, teamwork, and fostering engagement.

#### 3.3.1 *Impact on Makerspace Learning*

Due to COVID, the expectation of always having a remote option has become normalized; therefore, instruction teams for makerspace centered courses should continue to facilitate hybrid learning, even though it is more time intensive. The post-COVID learning environment has created a unique opportunity to develop novel curriculum and classroom infrastructure to support hybrid, hands-on learning. For example, students can submit 3D print jobs from home or conduct experiments while remotely controlling a test set-up. Sharing CAD files with teammates using file sharing applications like GrabCAD or AutoDesk Drive facilitates remote collaboration, ultimately resulting in achieving learning outcomes, meeting deadlines, which ultimately contribute to a higher quality final product. While many universities are expanding the availability of online courses, makerspace-oriented courses should attempt to follow suit. Industry has also pivoted towards hybrid work environments, and preparing students to effectively collaborate on hybrid hands-on projects will better prepare them for the realities of the professional workplace.

#### 3.3.2 *Project Specific Improvements*

Many lessons were learned from this first implementation of the Pokémon Challenge. Specifically, running an elaborate hands-on design-build-test experience is labor intensive. Although time-consuming, evaluating individual progress and customizing interim milestones held teams accountable and provided an opportunity for the teaching team to mentor them to be successful. Many students waited until the day before a deadline to work on their projects leading to issues with availability of the 20+ 3D printers and two laser cutters. The design reviews were helpful for streamlining grading as instructors were able to provide immediate feedback that teams could use.

The performance index can also be adjusted so teams would not feel discouraged, and more teams could be successful. This would include not penalizing them for hitting the backboard, and awarding points for landing in the End Zone even if not directly on the target. Furthermore, the

term project would likely be started earlier in the quarter despite students not having any CAD skills yet, to spread the workload and get them rapid prototyping earlier.

Involving companies or employers into the project may not only help introduce students to the industry, but also provide more “authenticity” to the project. This may also incentivize students to not neglect the portions of the project focusing on technical communication skills. Finally, following up with students later in their studies can also help assess how well this project prepared them to take their upper-division courses.

#### **4. Conclusions**

Overall, students found the Pokémon Challenge to be a rewarding experience and recognized that student learning outcomes were met. They were grateful at the ability to join remotely if they had to quarantine or were sick, which allowed them to participate effectively in their team project. Teams had to adjust to changes in personnel, a skill required in the practical world. While some teams struggled with team dynamics and many students complained about the workload, for the most part students enjoyed the team experience and were pleased with how far they had come in their designs.

#### **Acknowledgements**

The authors would like to acknowledge the EnVision Maker Studio at UC San Diego for their enthusiastic support of this project, especially the Director, Colin Zyskowski, who helped build test setups, purchased materials and supplies, and trained his EnVision staff to support the project. The authors would also like to thank the other two Teaching Assistants in the course, Andres Rodriguez and Ezra Lee, for their excellent support of the students throughout the quarter. Implementation of this labor intensive project could not have been achieved without their support.

#### **References**

- [1] L. Van Den Einde, J. Tuazon, D. Dodgen, “Make Rube Cube! A Case Study in Teaching Engineering Graphics Through an Experiential Project for Freshmen Structural Engineering Students”, In Proceedings of ICERI2017, 2017, pp. 8233-8243.
- [2] Terstiege, G., *The Making of Design*, Ed.; Switzerland, Birkhauser: Basel, 2009.
- [3] J. Loy, “eLearning and eMaking: 3D Printing Blurring the Digital and the Physical”, *Education Science*, vol. 4, no. 1, pp. 108-121, 2014. doi:10.3390/educsci4010108.
- [4] Schuster, P., & Davol, A., & Mello, J. Student Competitions The Benefits And Challenges, In Proceedings of 2006 ASEE Annual Conference & Exposition, 2006. 10.18260/1-2--1055.

- [5] Phillip C. Wankat, "Undergraduate Student Competitions." *Journal of Engineering Education*, vol.94, no. 3, pp. 343-7, 2005.
- [6] Brake, N. A., & Selvaratnam, T. (2020, June), "Peer Mentorship and a 3D Printed Design-Build-Test Project: Enhancing the First Year Civil Engineering Experience", In *Proceedings of 2020 ASEE Virtual Annual Conference*, 2020. 10.18260/1-2--35045
- [7] S. G. Bilen, T. F. Wheeler, and R. G. Bock, "MAKER: applying 3D printing to model rocketry to enhance learning in undergraduate engineering design projects," In *Proceedings of 2015 ASEE Annual Conference & Exposition*, 2015, pp. 26–1111.
- [8] Przirembel, "Integrating the Product Realization Process (PRP) into the Undergraduate Curriculum", ASME International, 1995, ISBN 0-7918-0126-8.
- [9] Duesing, P., & Baumann, D., & McDonald, D. "Learning And Practicing The Design Review Process", In *Proceedings of presented at 2004 ASEE Annual Conference*, 2004, 10.18260/1-2--12974.
- [10] Vollaro, M. "More Than Science Fair Fun: Poster Session As An Experiential Learning Activity In The Classroom" In *Proceedings of 2005 ASEE Annual Conference*, 2005. 10.18260/1-2--14662
- [11] D. B. Hamidreza & K. Knight, "Exploring Student Academic Motivation and Perceptions of Teamwork and Communication" In *Proceedings of 2021 ASEE Virtual Annual Conference*, 2021 <https://strategy.asee.org/37146>
- [12] M. F. Ercan and R. Khan, "Teamwork as a fundamental skill for engineering graduates," In *Proceedings of 2017 IEEE 6th International Conference on Teaching, Assessment, and Learning for Engineering (TALE)*, 2017, pp. 24-28, doi: 10.1109/TALE.2017.8252298.
- [13] Y. Liu, A. Vijay, S. M. Tommasini, and D. Wiznia, "Hands-on engineering courses in the COVID-19 pandemic: Adapting Medical Device Design for remote learning," *Physical and Engineering Sciences in Medicine*, vol. 44, no. 1, pp. 195–200, 2021.
- [14] M. Galaleldin, F. Bouchard, H. Anis, and C. Lague, "The impact of Makerspaces on Engineering Education," In *Proceedings of the Canadian Engineering Education Association (CEEA)*, 2017.
- [15] R. Li & J. Bringardner, "Understanding remote student motivation in hybrid and remote engineering lab modes", In *Proceedings of 2021 ASEE Virtual Annual Conference*, 2021.