

Incorporating Makerspace Design and Fabrication Activities into Engineering Design Graphics

Ms. Jan Edwards, College of Lake County

Jan L. Edwards is an Associate Professor of Engineering at the College of Lake County in Illinois. She received her Bachelor's and Master's degree in Materials Science and Engineering at Michigan Technological University. Ms. Edwards teaches general engineering courses, manages outreach initiatives and the CLC Baxter Innovation Lab at the community college. She is also serving as the Principal Investigator on the college's NSF S-STEM grant, Building an Academic Community of Engineering Scholars.

Prof. Rob Twardock, College of Lake County

Rob Twardock is an engineering professor at College of Lake County in Grayslake, Illinois since 2000. Rob is a graduate of the University of Illinois Urbana-Champaign with a B.S. and M.S. in Civil Engineering. He worked as a consulting engineer in Michigan and Illinois for 10 years prior to starting to teach at Mt. Hood Community College in 1998. Rob is the Co-Department Chair of Engineering Transfer and teaches all lower division engineering courses offered.

Incorporating Makerspace Design and Fabrication Activities Into Engineering Design Graphics

Abstract

This evidence-based practice describes the incorporation of an original design project coupled with the use of a makerspace into the Engineering Design Graphics curriculum. This design project has given students more of a connection to engineering work and provides a strong foundation for developing an engineering identity. This is further enhanced through the use of a makerspace environment which enables students to fabricate, inspect, and iterate their designs. The measurable outcomes for the current project will focus on student engagement and perceived learning gains. The results of a survey measuring students' perspectives on the value of the course project work on their learning will be presented. The objective of this paper is to disseminate the positive results of the project and encourage the incorporation of makerspace-based design projects into the Engineering Graphics curriculum, with a focus on the community college setting.

Engineering Design Graphics is a gateway introductory course in the Engineering curriculum that has high potential for engaging and retaining freshman engineering students. An example of a group project involving a simple marble lift will be presented that incorporates open-source design process content, engineering principles, functional analysis, lab safety, buildability, hands-on prototyping, exposure to various desktop manufacturing methods, inspection and measurement. The project is integrated throughout the course and includes reverse engineering, sketching, 3D solid modeling skills, development of detailed design drawings, design revisions, as well as verbal and written communication. The increased emphasis on project work using the makerspace has proven popular with students, increasing their engagement, enthusiasm, and attendance.

This paper details the resources, curriculum, and projects used in Engineering Design Graphics that provide experiential learning experiences. Each step of the project will be mapped to concrete skills, standard course material in the textbook and course outcomes. In addition, the paper will explore the impact of the makerspace environment, student responses to the project format and thoughts on further implementation in future semesters, including dissemination across multiple sections and the development of various iterations.

Introduction

Integrating experiential learning into the undergraduate engineering curriculum is a key factor in improving learning outcomes, retention, and academic performance for all students [1], [2]. In Engineering Design Graphics, opportunities exist to integrate experiential learning, however many schools, particularly community colleges, are limited by a lack of lab space dedicated for this purpose. While students are still able to carry out a design project and benefit from many of the learning outcomes desired, the limitations of space and time remain. An open access makerspace enables broader learning outcomes to be achieved including hands-on experience with tools and equipment used for prototyping, the ability to iterate designs quickly, as well as

developing some of the teamwork and workplace professionalism skills associated with project work typically found in industry.

Freshman and sophomores studying engineering benefit a great deal when they network and bond through the shared experiences of project work. Community college students, in particular, exhibit improved retention and graduation rates as a result of building a shared sense of community [3], [4]. With their commuting status and typically heavy part-time job workload, community college students don't often socialize outside of class, which leads to isolation both socially and academically. Project based learning can help this by promoting a student's sense of self-efficacy, building their confidence that they can succeed at "real engineering", and helping build a support network of professors and peers that improves a student's chances of persisting [5]. This paper focuses on the integration of a cost-effective, easy to implement design project that is appropriate for any freshman-level Engineering Design Graphics course but is particularly appropriate for community college settings.

Background

Development of Dedicated Makerspace

Spurred by a requirement to integrate design projects into the Engineering Design Graphics curriculum by the Illinois Community College's Illinois Articulation Agreement (IAI), the College of Lake County (CLC) Engineering department developed design projects for Engineering Design Graphics and simultaneously pursued funding to develop lab space that would allow students to prototype their designs. In 2017, the Baxter International Foundation funded a renovation of existing lab space to allow the development of the Baxter Innovation Lab on CLC's Grayslake, Illinois campus.

The lab is modeled on MIT's Fab Foundation charter. It provides the space and equipment for individuals and groups to design and fabricate prototypes (not production) with a variety of software, tools and equipment including equipment for 2D and 3D CAD design, woodworking, metalworking, electronics, desktop digital fabrication, programming and other skill sets required by the modern STEM workforce.

A unique aspect of the Baxter Innovation Lab is that it is an open lab that welcomes any student to use it for project work, studying, collaborating, or meeting with fellow students. It is staffed mostly by student interns; between 8 and 12 students each semester get experience in a work atmosphere that resembles a small prototype shop. They maintain and troubleshoot equipment, work with "clients", enforce safety, run workshops, develop equipment expertise, and assist with the long-term development of the lab mission and goal fulfillment.

Need for Change in Engineering Design Graphics

Engineering Design Graphics has many concepts that can be dry and discourage freshman engineering students from persisting when taught with a theoretical focus. This is reflected in the historically high attrition rate observed for this course. CLC's Engineering program has also struggled with overall retention, especially amongst underrepresented students. Our National Science Foundation S-STEM grant addresses some of these issues by incorporating activities

aimed at increasing self-efficacy and sense of belonging. The opportunity to improve experiential learning in Engineering Design Graphics using the Baxter Innovation Lab resulted in the development of new learning outcomes and the project work featured in this paper.

In addition, many engineering students lack practical knowledge of how to use basic hand and power tools, measure for fabrication, and inspect completed parts by comparing with the original design. This often results in students' virtual designs being impractical to manufacture. The project work attempts to bridge the gap between the virtual skill set and understanding engineering requirements while at the same time making the class more engaging and fun.

Desired Learning Outcomes

With the ability to have students work in the Baxter Innovation Lab, the CLC Engineering Graphics lesson plans were re-evaluated with the following desired learning outcomes in mind:

- Analyze the engineering functions of existing products.
- Create functional description of the design intent, including design objectives and constraints.
- Display competency and safe practices using essential shop equipment
- Apply sketching, 3D solid modeling, and CAD drawing skills to convey design ideas effectively.
- Apply design principles and rationale in a structured, realistic, and original engineering project application.
- Work in a team to generate, analyze, evaluate and select among engineering design solutions to meet specified requirements
- Communicate the results of the design process, including working drawings (detailed part drawings and assembly drawings) verbal, and written presentations
- Build functional physical model of a design and test it
- Inspect fabricated parts and report on deviation from allowable tolerances
- Explain deviations in allowable tolerances based on manufacturing method

These outcomes are in addition to the traditional outcomes associated with engineering graphics such as multiview drawing, pictorials, sections, dimensioning, tolerancing, assembly drawings, etc. Hoped for outcomes not explicitly listed include generating more hands-on experiences to balance all the theoretical work included in lower division engineering coursework, as well as allowing the students to have some fun with their projects. We also intended to use the project work to build a sense of community and belonging amongst our students through a group project. Thus, extending the impact of our S-STEM objectives to a broader audience.

Engineering Design Graphics

Engineering Design Graphics is a freshmen level introductory course for students majoring in Mechanical, Industrial, and Civil Engineering, CAD, CNC, Mechanical Engineering Technology, among others. After revisions were made to meet IAI learning outcomes, the course is split relatively evenly between traditional engineering graphics concepts, the design process, and 3D solid modeling, including the development of detailed part and assembly

drawings. The example project work shared here has been optimized to fully integrate the concepts rather than offering a discrete experience.

Project Implementation

The project developed for this course involves a product that students enjoy working with - a simple marble lift. The marble lift is inexpensive, and its individual parts are relatively easy to build in a short period of time. It incorporates a simple cam shaft design. It also provides an opportunity for reverse engineering and a design phase that would improve the existing design. Two phases of the marble lift project are incorporated into the class: Part 1 – Reverse Engineering, and Part 2 – Marble Lift Automation Design and Prototyping.

Part 1 - Marble Lift Reverse Engineering

In the first part of the project, students are presented with a finished marble lift project, provided with a set of working drawings, and challenged to reverse engineer the product.

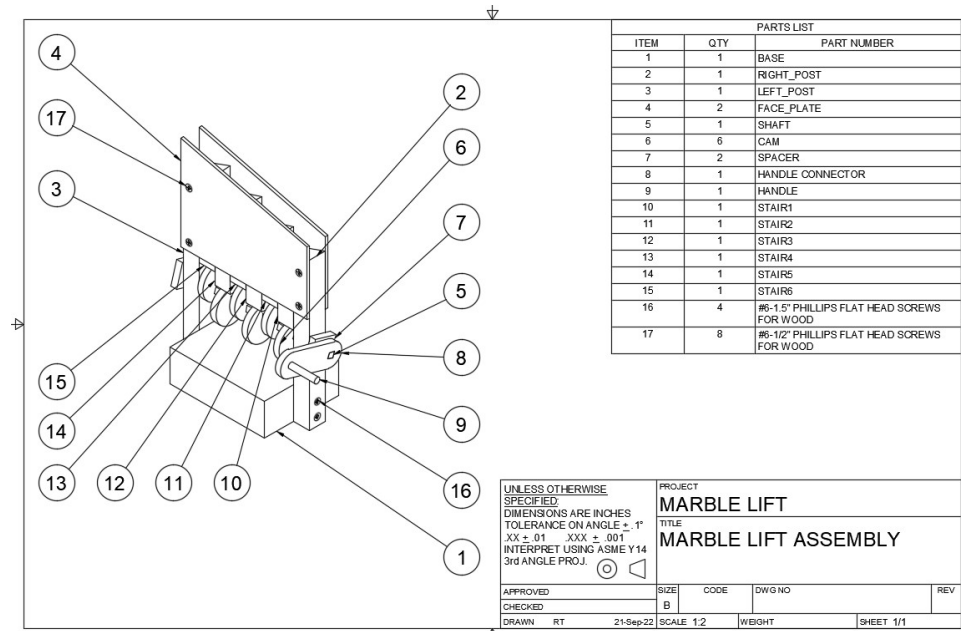

Figure 1 – Marble Lift Assembly Drawing



Figure 2 – Picture of Marble Lift Prototype

The reverse engineering project includes the following steps:

Functional Analysis – Students perform a functional analysis of each part, evaluating its basic function in the overall design using object verb pairs.

Sketching - Each student is required to sketch at least 3 parts as an oblique or isometric using pictorial sketching techniques covered concurrently in lecture.

Safety Training – All students are given an orientation to the lab, complete general lab safety training, and sign a user safety agreement. The development of safe practices and habits are emphasized.

Development of Equipment Expertise – Students self-select members of team to be equipment “experts”. Each equipment expert completes hands on basic training including basic operation and safety (typically miter saw, drill press, and laser cutter).

Use of Detailed Part Drawings – Teams evaluate the existing detailed part drawings and prepare materials for fabrication. Digital calipers and rulers are provided. Students are encouraged to layout materials for fabrication considering the manufacturing technique being used. This is the first exposure to detailed part drawings.

Fabrication - Given stock materials, teams fabricate the parts required to complete the marble lift. The posts, stairs, and base are typically made on the miter saw, holes on the drill press, and face plates and cams are made on the laser cutter with the assistance of lab interns. For many

students, this is the first use of shop tools or digital fabrication techniques. Students are allowed to make mistakes and re-fabricate parts as needed. It is common to learn their measurements when laying out parts for fabrication may have been inaccurate or unrealistic.

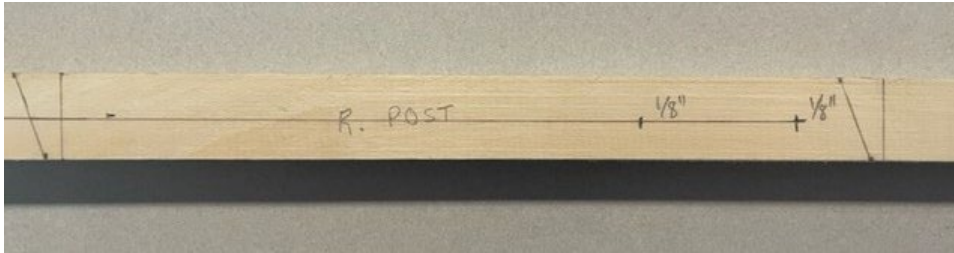

Figure 3 – Picture of Marble Lift Fabrication

Inspection - Students inspect a representative sample of the fabricated parts and compare with the design dimensions. An inspection report is completed documenting as-built versus design dimensions, checking if parts were within acceptable tolerances, and explaining any deviations.

Names of Group Members:
Class Day and Section (e.g. TR Section 003)

Part Title	Dimension Type	Design Dimension	As Made Dimension	Percent Error (%)	Explanation of Error
Example	Width	2.0"	1.9"		5 Location of mitre saw cut
	Height	5.0"	4.8"		4 Thickness of miter saw blade
	Depth	1.0"	1.0"		0 none
Stair 1	Width	0.75 in			
	Depth	0.74 in			
	Height (Major)	2.75 in			
	Height (Minor)	2.50 in			
Stair 5	Width	0.75 in			
	Depth	0.74 in			
	Height (Major)	3.75 in			
	Height (Minor)	3.50 in			
Left Post	Width	.74 in			
	Depth	.75 in			
	Height (Major)	8.00 in			
	Height (Minor)	7.75 in			
	spacing between top pilot holes	2.25 in			
	spacing between bottom pilot holes	.625 in			
	Shaft Guide Hole Diameter	.375 in			
	Shaft Guide Hole Vertical Offset	3.25 in			
Shaft Guide Hole Horizontal Offset	.375 in				

Figure 4 – Example Inspection Report

Assembly and Testing - The marble lift is assembled and tested, and the lift's performance is compared with the model. Iterations are encouraged to achieve optimal performance. Students are also encouraged to reflect and report on deficiencies in the original design and the performance of the as-built design.

Communication of Results - Teams prepare a written report and oral presentation summarizing their findings. Content includes functional analysis, manufacturing processes, measurement and testing, performance of completed prototype, and lessons learned, including suggestions for improvement of the original design.

Part 2 - Marble Lift Automation Design and Prototyping

In the automation design and prototyping part of the project, teams are challenged to respond to a fictional client “CamsRUs” request to automate the existing marble lift design which required a manual crank operation to raise the marble. Project teams are encouraged to evaluate flaws in both the original design and their fabricated prototype from the reverse engineering part of the project. A motor, switch, and control board assembly are provided. Constraints included for the project are as follows: size (18”W x 12”D x 12”H), materials (PVC piping, MDF, foam, plywood, cardboard, stock lumber, miscellaneous hardware, additional hardware such as chains, gears, pulleys, belts, etc., acrylic sheets, and 3D printed parts), schedule (typically 6-7 weeks), and cost (less than \$30 – including all materials and hardware but excluding the motor assembly).

The goals communicated to the students for this part of the project include:

1. Make revisions to the current prototype as needed to improve performance, including functionality and reliability.
2. Design a motorized version of the product using the DC power jack, controller, switch, and motor provided in order to send the marble on a continuous loop without human intervention. Your design should include elements that hold and allow access to the motor, controller switch, and input jack in a secure manner.
3. Incorporate structural elements to maximize the time, complexity, fun, and innovative nature of the path of the marble. Incorporating engineering principles for educational purposes is rewarded.
4. Demonstrate the use of a 3D printer, laser cutter, and/or CNC mill to fabricate custom parts.
5. Present the finished design with a functional prototype to the CamsRUs company with the goal of having it green-lit for production.

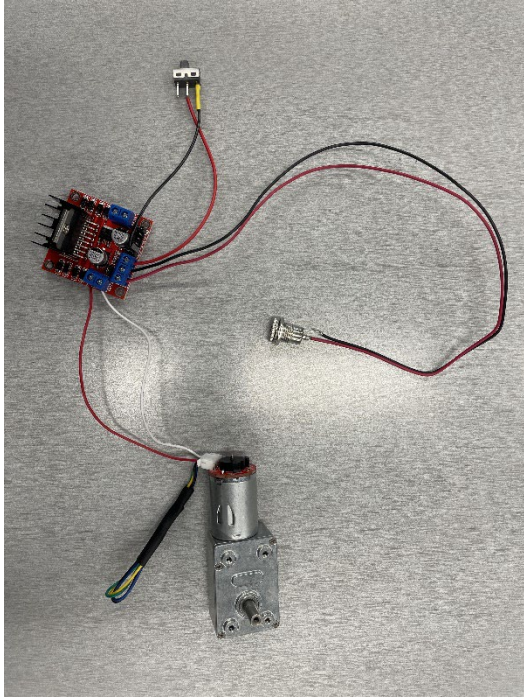

Figure 5 – Motor, Switch, Control Board, and Power Input Assembly Provided

The design and prototyping part of the project includes the following steps:

Design Process – Project teams work through a prescriptive design process covered in lecture. The design process lecture materials used were developed internally, and are available as open source, in order to keep the cost of textbooks down. The design process used includes the following steps:

Typical Design Process



Figure 6 – Typical Design Process

Student teams work through the steps in the design process in a methodical approach, documenting each step with notes and sketches in an engineering notebook. Lecture content that is applied includes methods to form a proper problem identification, prioritization of project

goals using a pairwise comparison chart, the development of final design criteria, project metrics, and a decision matrix.

Problem Identification

Development of Design Criteria

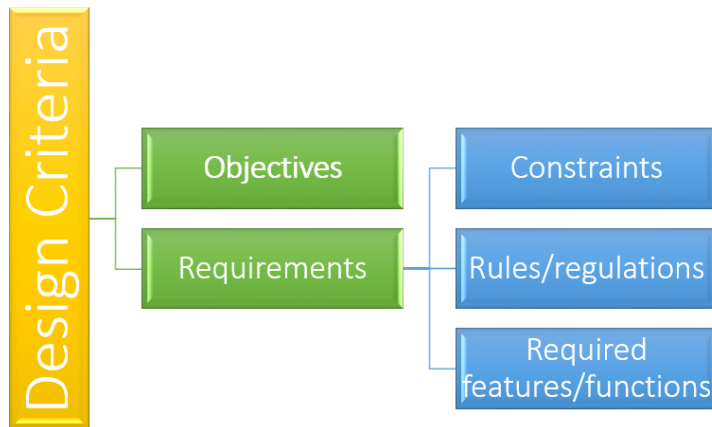

Figure 7 – Design Criteria

Students are required to use and document a formal brainstorming technique and generate a minimum of three conceptual designs. Iterations are encouraged, to combine and improve ideas as they are generated.

Evaluating prototyping options – Students’ natural tendency is to focus on one of the first design ideas generated. While the enthusiasm for design ideas is encouraged, an objective comparison of different conceptual design alternatives is required, with the class motto “the first design is rarely the best” infused often throughout class discussions. The use of a decision matrix is required. The decision matrix includes design criteria with metrics and a scoring mechanism to rank each design alternative.

Decision Criteria	Point values	Design 1	Design 2	Design 3
Function	20	20	15	5
Aesthetics	12	12	6	12
Cost	8	4	5	8
Size	18	18	18	18
Efficiency	8	8	5	8
Reliability	24	24	20	2
Total points	100	94/100	77/100	54/100

Figure 8 – Example Decision Matrix

Development of prototype - Once a conceptual design is selected, teams divide responsibilities to fabricate a functional prototype. Since the use of a variety of equipment is required, team roles are assigned based on fabrication techniques. Where appropriate, low fidelity prototyping is encouraged to keep costs down and to expedite the schedule, allowing multiple iterations. Teams typically underestimate the complexity of achieving their goals; periodic milestone deadlines set by the instructor help teams appreciate gaps in their design or fabrication process and schedule. The use of customized parts is encouraged, and the Baxter Innovation Lab interns assist with the fabrication of parts requiring laser cutting, CNC milling, or 3D printing. Interns typically require a consultation prior to starting a custom part to ensure design for manufacturing has been taken into account, and to help the student understand the technology being applied.

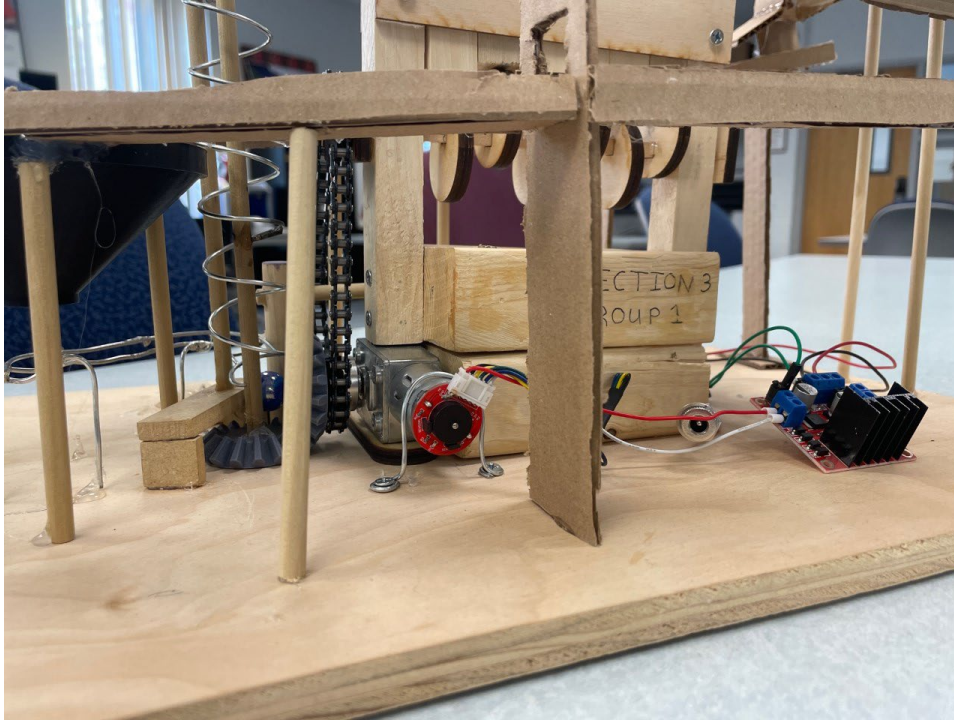

Figure 9 – Example of Automated Marble Lift Design Prototype

Inspection and Testing – Design teams are encouraged to test their prototypes and perform iterations well before the final deadline. A final bill of materials is required with the total cost of all the parts submitted. The time of the marble to complete one loop is recorded. Reliability is verified by testing continuous operation without errors. During this time, team members typically exchange design and fabrication ideas and incorporate them as appropriate.

Design Communication – Teams are required to submit a written report including:

- A one paragraph problem description,
- Project goals, including those explicitly state in the assignment and those generated by the team
- Project Objectives
- Project Requirements (constraints, rules/regulations, required features/functions)
- Finalized Design Criteria ranked using a pairwise comparison chart,
- Metrics for each Design Criteria based on a 10-point scale
- Documentation of brainstorming process used
- 3 distinct conceptual design sketches
- Presentation of detailed design
- Evaluation of performance
- Lessons learned

Assessment and Evaluation

Although course revisions started in 2016, the fall semester of 2022 was the first time the marble lift project was embedded from start to finish. Data were collected anonymously at the end of the semester from two sections of the course taught by the same instructor. Of the 40 students in the courses, 38 students completed the survey.

The Student Assessment of their Learning Gains (SALG) was administered to measure learning gains, attitudinal shifts and the impact of the methods used to present the material. The SALG was constructed and validated with support from the National Science Foundation [6]. The tool, which is available online, has been used by more than 24,000 instructors to assess more than a half million students. The structure of the survey is integral to the design; however, instructors are able to add questions specific to their course content.

Since the survey is adaptable in both the content and timing of its application, the original authors [6] offer advice on ensuring reliability and validity. At this time, the data collection using the current variation of the survey is insufficient to comment on reliability. Validity will be examined in future work where the perceived gains will be compared with measurable course assessments. The data collected in this study was anonymous to encourage full participation.

Students were asked to assess what gains occurred in their understanding and performance of the concepts detailed in the course learning outcomes (e.g., Apply design principles and rationale or Work in a team to produce design solutions) using a five-point Likert scale from “no gains” to “great gains.” In addition, self-reported gains were examined for lab skills and an opportunity to reflect on the help offered by different pedagogical techniques. Each survey topic also included a free response section. The complete survey tool is listed in the Appendix. These indicators and student feedback allow analyses of the impact of various aspects of the course design. In future semesters, additional data will be collected and compared.

Survey results

When asked “As a result of your work in this class, what gains did you make in your understanding and performing of the main concepts?”, 45% reported having great gains, 39% reported good gains and the remaining 16% reported moderate gains. There were no students who selected little to no gains. In general, the students expressed significant gains for the majority of the concepts as shown in Figure 10. Explaining the theory and proper use of tolerances was the concept with the smallest reported gains. Without the use of a pre-survey, it is unknown if this is due to a strong prior understanding or if this is an area for improvement. Specific lab skills which had a high response rate indicating great gains included “Designing for 3D printing” (78.9%) and “Using Fusion 360” (86.8%). In comparison, more traditional shop tools had great gains response rates closer to 40%. That is still indicative of a valuable experience for students who may have taken more theoretical college preparation courses in high school.

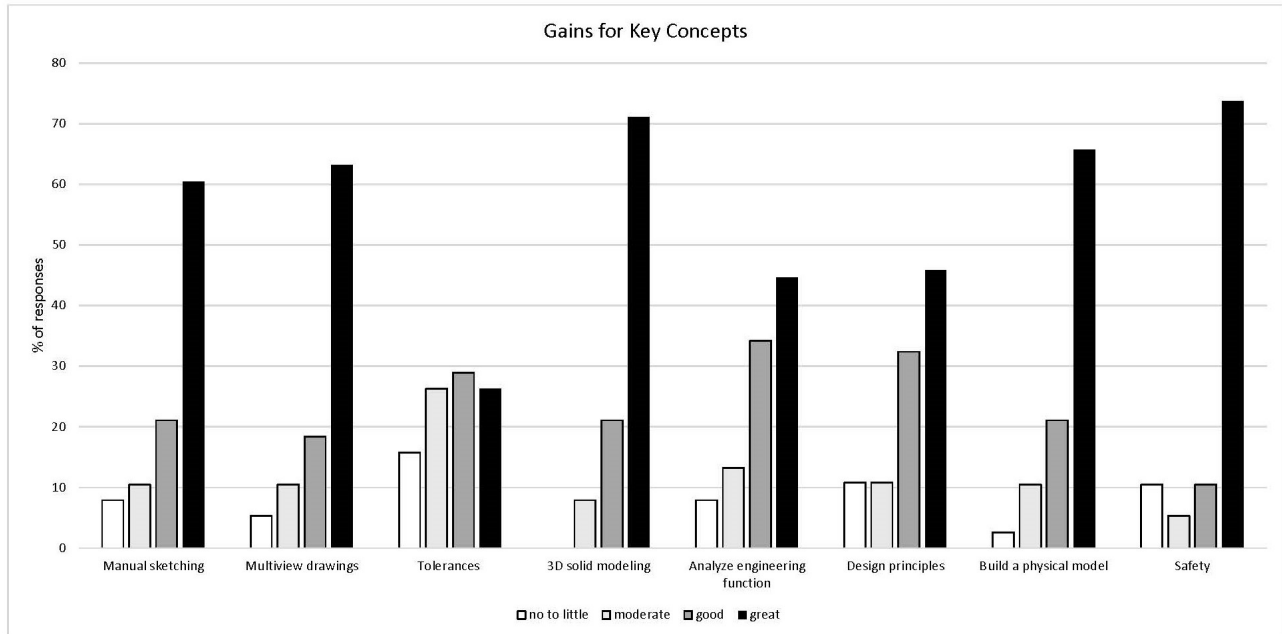

Figure 10 - Survey data of student reported gains in understanding and performance.

In addition to the technical understanding, great gains were reported in understanding and performing with respect to “Communicate the results of the design process” and “Work in a team to produce design solutions” (see Figure 11) which are essential for employment. Note, when “Working effectively with others” was defined as a standalone skill rather than as part of the design process the gains were slightly lower. The other set of gains that was particularly relevant to persistence and retention, were responses to the following “Interest in taking or planning to take additional classes in this subject”, “Confidence that you understand engineering material”, and “Willingness to seek help from others (teacher, peers, intern) when working on academic problems.” All three of these items had a combined response rate of good and great that exceeded 68%. The willingness to seek help appears to correlate with the improvements in teamwork. In addition, as a student run lab, it seems likely that seeking help from a student intern has a lower risk barrier in comparison to relying on the instructor for technical support.

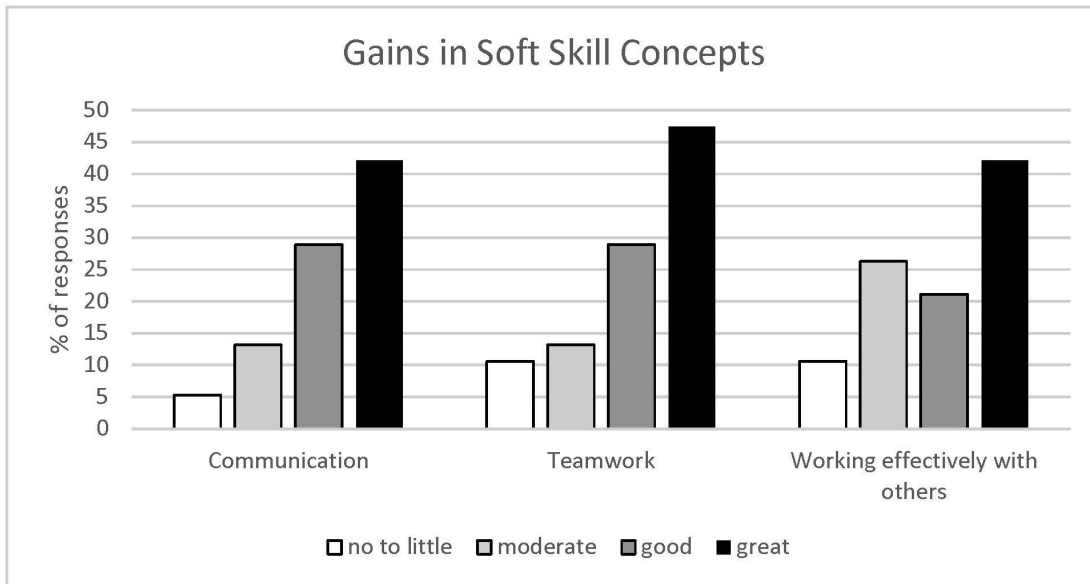

Figure 11 - Student reported gains in understanding and skills.

Each concept for the learning outcomes was introduced using a variety of techniques as shown in Table 1. The course structure enables the full experiential learning cycle as defined by Kolb [7] to be enacted multiple times. Concrete experiences are provided to introduce concepts. Individual and team reflection assignments are given to interpret the experiences. More theoretical information is offered in the form of textbook readings and lectures. The knowledge is then applied through active experimentation during the next round of the project.

For example, understanding the theory, notation and application of tolerances is a standard course outcome for an engineering graphics design course. A concrete experience with tolerances occurs as the students begin the reverse engineering portion of the project. Students observe that the example marble lifts perform inconsistently. This provides an opportunity to consider why there is variation in the components and the impact on functionality. A few weeks later, dimensioning is more formally introduced, and the concept of tolerances is discussed with respect to datum dimensioning and significant figures. In the same time frame, the students are inspecting the parts their team has created. The report each team generates includes calculating the percentage of error and determining the cause.

These concrete experiences are reflected upon by the individual students and in class discussions. The common experience enables the entire class to consider the impact of the manufacturing method chosen and the amount of acceptable variation. The discussion closes with their key takeaways on how to reduce variation in their next build.

Theoretical understanding is established, as the next project begins, by completing a chapter in the textbook focused on tolerancing. This introduces the standard notation for detailed drawings, types of fit and design intent.

Active experimentation will occur as the prototypes start to evolve in the next stage of the project both with respect to determining the manufacturing method as well as when making adjustments

for improved functionality. This will initiate a second cycle within the team as they complete new experiences, reflect on the issues with the prototype, refer to their notes and text, and then actively experiment again to find a solution.

Concepts	Part 1 - Reverse Engineering	Lectures / videos / discussions	Textbook problems	Reflection	Part 2 - Design and Prototyping
Manual sketching	X	X	X		X
Multiview drawings	X	X	X		
Tolerances (theory and application)	X	X	X	X	X
3D solid modeling	X	X	X		X
Analyze engineering function	X	X		X	X
Design principles (rationale and application)	X	X		X	X
Build a physical model	X			X	X
Safety	X	X			X
Teamwork	X				X

Table 1. Mapping of course learning outcomes relative to the specific project

Note, a secondary individual project also provides opportunities for students to apply their knowledge gained. The individual project requires a physical build and focuses on generating detailed drawings. Thus, students sharpen their multiview drawing and tolerance skillset. It also enables the student to have ownership and sole decision-making power.

The students' perception of what classroom methodology most helped their learning matches the evidenced based practice of active learning. Figure 12 displays the percentage of students who responded "great help" to the following question "How much did each of the following aspects of the class help your learning?" This suggests that the introduction of this project is positively

impacting our students' learning outcomes. It is interesting to note that the act of dialog and reflection are as important as participation. This is evident in that listening to discussions was perceived as a greater help than participating in discussions.

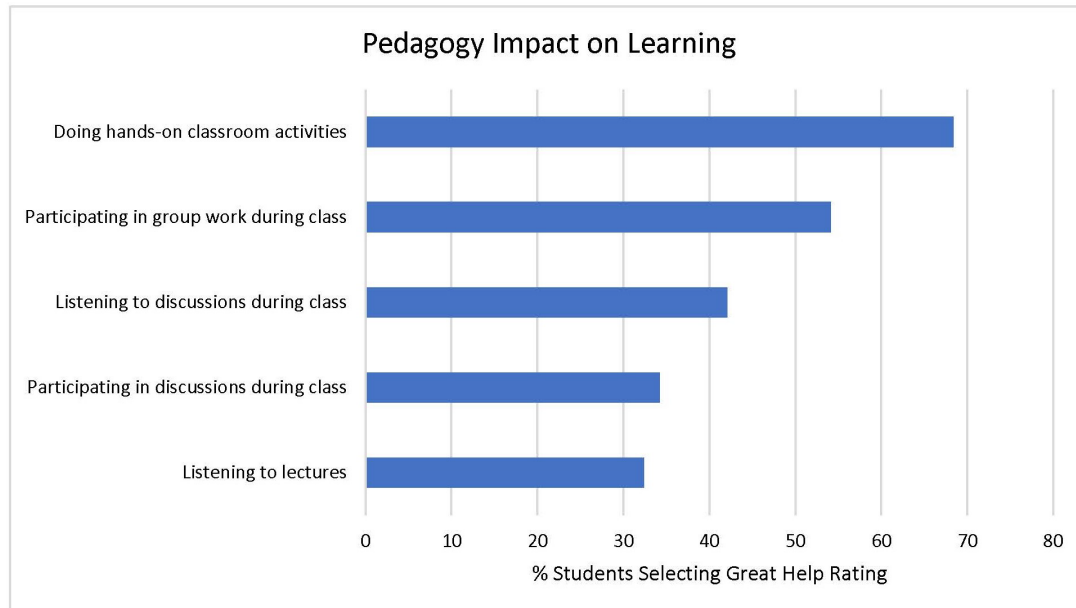

Figure 12 - Student perceived help in learning based on pedagogy

Student Feedback

The free response sections of the survey, as well as student ratings of instruction, provided an additional glimpse into the student perspective on this course. The iterative nature of both learning and design were summarized well by the following statement.

“It helped me to expect failure and not to be afraid of it. I learned that failure is good in order to be able to improve upon from it and keep thinking of other solutions.”

Increased motivation was shared by other students.

“Being able to work in the lab and with physical things really helped me understand the process of engineering a design and manufacturing it.”

“I think this course was the most fun one I had this semester and makes me excited for the future.”

“I’ve found the projects to be the most exciting and engaging part of the class.”

“Hands-on individual and group projects and working with industry CAD programs increased my field experience.”

This is not to say that the curriculum was free of challenges. Group projects are known for their ability to support socially constructed learning but students frequently struggle with teamwork at some point in the project. Often with increased frequency as deadlines draw near.

“Sometimes the group workflow can be like nails on a chalkboard, other times we struck a good rhythm.”

“I believe that there should have been more time dedicated to the final projects towards the end of the semester. There seemed to be a bit of a time crunch, and I believe that many students would appreciate if this were to be more spread out.”

“Okay, I’m just generally terrible with multiple large projects being assigned at the same time, but I’m sure I’m not alone in that. The marble related projects are very cool and were enjoyable, I just would have liked them to be maybe a bit more spread out over the time.”

Conclusions and Future Work

This paper presented the results of a design project incorporated into Engineering Design Graphics at the College of Lake County that leverages a makerspace to increase student engagement, and improve learning outcomes. The project’s two parts are spread out over the semester to allow full integration of course topics. They are introduced, practiced, and reinforced at multiple points during the semester. The project is a relatively inexpensive way to blend hands-on fabrication, prototyping, inspection of parts made by students with the traditional theory covered in the lecture portion of the course.

The project was well received by students and multiple faculty teaching the course. Students report positive gains in communication, teamwork, and working well with others. They also indicate the hands-on class activities and group work contributed the most to their learning outcomes, while lecture contributed least, reinforcing the benefits of the project work in the lab. Anecdotally, students can be observed having fun in the class, engaging with their peers, and gaining confidence working with lab tools and equipment.

In upcoming semesters, the project will be further refined, considering feedback from students and instructors. The impact of the project on retention, completion rate, and learning outcomes will be further studied. As the project was implemented following COVID-19 restrictions, it is difficult to fully assess the impact until student attendance, modes of instructions, and other COVID impacts have stabilized.

As shown in the student comments, spreading the project out over time will address student concerns over it being too compressed. Changes to the design challenge may be made in order to keep the project fresh for each group of incoming students.

References

[1] E. J. Theobald, M. J. Hill, E. Tran, S. Agrawal, E. N. Arroyo, S. Behling, N. Chambwe et al., "Active learning narrows achievement gaps for underrepresented students in undergraduate science, technology, engineering, and math," *Proceedings of the National Academy of Sciences*, vol. 117, no. 12, pp. 6476-6483, 2020.

- [2] H. Li, A. Öchsner, and W. Hall, "Application of experiential learning to improve student engagement and experience in a mechanical engineering course", *European Journal of Engineering Education*, vol. 44, no. 3, pp. 283-293, 2019.
- [3] T.L. Strayhorn, *College Student's Sense of Belonging: A Key to Educational Success for All Students*. New York: Routledge, 2012.
- [4] V. D. Carales and D. L. Hooker. "Finding where I belong: How community colleges can transform their institutional environments to facilitate students' sense of belonging on campus." *Journal of Applied Research in the Community College*, vol. 26, no. 2, pp. 41-50, 2019.
- [5]. W.Hung, M. Moallem, and N. Dabbagh, "Social Foundations of Problem-Based Learning," in *The Wiley Handbook of Problem-Based Learning*, W.Hung, M. Moallem, and N. Dabbagh. Ed. Wiley, 2019, pp. 51-79.
- [6] E. Seymour, D. Wiese, A. Hunter, and S. M. Daffinrud, "Creating a better mousetrap: On-line student assessment of their learning gains," Paper presentation at the *National Meeting of the American Chemical Society, San Francisco, CA., 2000*.
- [7] D. A. Kolb, *Experiential learning: Experience as the source of learning and development*. FT press, 2014.

Appendix

Student Assessment of Learning Gains Survey Adapted for Engineering Design Graphics

1. As a result of your work in this class, what GAINS DID YOU MAKE in your **UNDERSTANDING and PERFORMING** each of the following? Scale (no gains, a little gain, moderate gain, good gain, great gain, not applicable)
 - a. The main concepts explored in this class
 - b. Using manual sketching techniques to effectively convey design ideas.
 - c. Generating isometric and oblique pictorial sketches
 - d. Producing a multiview drawing
 - e. Using dimensions and tolerances in detailed part drawings
 - f. Creating section views
 - g. Producing a primary auxiliary view
 - h. Explaining the theory and proper use of tolerances
 - i. Create a 3D parametric solid model
 - j. Analyze the engineering functions of products
 - k. Apply design principles and rationale
 - l. Work in a team to produce design solutions
 - m. Communicate the results of the design process
 - n. Creating functional description of the design intent
 - o. Build a physical model of a design and test it
 - p. Lab safety

2. As a result of your work in this class, what **GAINS DID YOU MAKE** in your **UNDERSTANDING** of each of the following? Scale (no gains, a little gain, moderate gain, good gain, great gain, not applicable)
 - a. How ideas from this class relate to ideas encountered in classes outside of this subject area
 - b. How studying this subject area helps people address real world issues
3. Please comment on **HOW YOUR UNDERSTANDING OF THE SUBJECT HAS CHANGED** as a result of this class. (Open ended)
4. Please comment on how **THE WAY THIS CLASS WAS TAUGHT** helps you **REMEMBER** key ideas.(Open ended)
5. As a result of your work in this class, what **GAINS DID YOU MAKE** in the following **SKILLS?** Scale (no gains, a little gain, moderate gain, good gain, great gain, not applicable)
 - a. Using hand tools
 - b. Using power tools
 - c. Designing for 3D printing
 - d. Designing for laser cutting
 - e. Working effectively with others
 - f. Preparing and giving oral presentations
 - g. Writing a technical report
 - h. Using Fusion 360
6. Please comment on what **SKILLS** you have gained as a result of this class. (Open ended)
7. As a result of your work in this class, what **GAINS DID YOU MAKE** in the following? Scale (no gains, a little gain, moderate gain, good gain, great gain, not applicable)
 - a. Enthusiasm for the subject
 - b. Interest in discussing the subject area with friends or family
 - c. Interest in taking or planning to take additional classes in this subject
 - d. Confidence that you understand engineering material
 - e. Willingness to seek help from others (teacher, peers, intern) when working on academic problems
8. Please comment on how has this class **CHANGED YOUR ATTITUDES** toward this subject (Open ended)
9. How much did each of the following aspects of the class **HELP YOUR LEARNING?** Scale (no help, a little help, moderate help, much help, great help, not applicable)
 - a. Listening to lectures
 - b. Participating in discussions during class
 - c. Listening to discussions during class
 - d. Participating in group work during class
 - e. Doing hands-on classroom activities
 - f. Group project: Marble lift reverse engineering and prototype
 - g. Group project: Design and build autonomous marble lift
 - h. Individual project: Designing and testing robot grippers
10. Please comment on how the **CLASS ACTIVITIES** helped your learning. (Open ended)
11. Please comment on **HOW OFTEN YOU PARTICIPATED** in class discussions and **HOW THE ATMOSPHERE IN THE CLASSROOM ENCOURAGED OR DISCOURAGED** your participation. (Open ended)