

# Teaching Engineering Design, Basic Circuit Design and Coding to First-Year Engineering Students Using a 3-D Printed Robotic Hand-Based Project

**Jason Morlock**

**Louis Josef Handwerker**

**Dr. Ludvik Alkhoury, New Jersey Institute of Technology**

Dr. Ludvik Alkhoury is the Lab instructor of Fundamentals of Engineering Design; a course that introduces engineering concepts to first-year engineering students.

**Dr. Jaskirat Sodhi, New Jersey Institute of Technology**

Dr. Jaskirat Sodhi is interested in first-year engineering curriculum design and recruitment, retention and success of engineering students. He is the coordinator of ENGR101, an application-oriented course for engineering students placed in pre-calculus courses. He has also developed and co-teaches the Fundamentals of Engineering Design course that includes a wide spectrum of activities to teach general engineering students the basics of engineering design using a hands-on approach which is also engaging and fun. He is an Institute for Teaching Excellence Fellow at NJIT and the recipient of NJIT's 2022 Excellence in Teaching Award - Lower Division Undergraduate Instruction, 2022 Newark College of Engineering Excellence in Teaching Award, and 2018 Saul K. Fenster Innovation in Engineering Education Award.

**Dr. Ashish D. Borgaonkar, New Jersey Institute of Technology**

Dr. Ashish Borgaonkar works as Asst. Professor of Engineering Education at the New Jersey Institute of Technology's (NJIT) Newark College of Engineering (NCE) located in Newark, New Jersey. He has developed and taught several engineering courses primarily in first-year engineering, civil and environmental engineering, and general engineering. He has won several awards for excellence in instruction; most recently the Saul K. Fenster Award for Innovation in Engineering Education. His research focuses on increasing diversity in STEM education and the STEM workforce. He has received multiple grants to run workforce development training programs as well as undergraduate research experience programs to train underrepresented minority and first-generation students. He is the Founding Director of NJIT's Grand Challenges Scholars Program. He also has worked on several research projects, programs, and initiatives to help students bridge the gap between high school and college as well as to prepare students for the rigors of mathematics. He is also involved in various engineering education initiatives focusing on the integration of novel technologies into the engineering classroom, and excellence in instruction. His additional research interests include water, and wastewater treatment, civil engineering infrastructure, and transportation engineering.

# Teaching Engineering Design, Basic Circuitry, and Coding to First-Year Engineering Students Using a 3D Printed Robotic Based Project

## Introduction

Traditional methods of teaching engineering design concepts are shown to be ineffective at promoting learning and high-level skill development [1]. Alternatively, building a foundation of problem-solving and critical thinking skills is essential for producing creative and effective young engineers. Experimentation and hands-on activities allow students to observe and explore real-world applications of fundamental theories and to develop a deep understanding of theoretical lessons [2].

In order to prepare students for the technologically advanced world they will enter after graduation, top universities are shifting their focus to design-centered instruction using technical skills as a toolbox [3], [4]. These concepts are often taught during the early stages of engineering education, typically in the first year of instruction. Students are expected to demonstrate design abilities in classes and projects throughout their education [3]. For instance, a cohort of university professors from the University of Malaga implemented robotic integration into their undergraduate course to promote hands-on learning using Lego NXT, something that was quite novel at the time [5]. The response from students showed improvement in identifying problems and designing solutions [5]. Moreover, a study by Onar *et al.* [6] claimed that mechatronic integration is necessary to ensure engineering students can compete in the workplace of the fourth industrial age after graduation. Project-based learning engages students with a learning experience that is hands-on and genuinely interesting.

In addition to the abovementioned skills, it has become crucial for contemporary engineers to acquire a solid background and proficient ability to program computers as these skills are needed in industry and engineering designs [7]. However, it has been reported that learning to program is hard and programmers suffer from a wide range of difficulties and deficits [3], [8], [9]. This artifact is manifested by high dropout and failure rates in programming courses [9].

In this evidence-based practice paper, we propose a method to teach first-year general engineering students 3D modeling, problem-solving and critical thinking skills, and coding, using an entertaining and engaging hands-on activity that uses a robotic hand model. Student participants in this study are a class of 54 first-year General Engineering (GEN) students at New Jersey Institute of Technology (NJIT) enrolled in Fundamentals of Engineering (FED 101-GEN) course [11]. Students in GEN major are a mix of students who are still-deciding what major they want to pursue and students who were asked to join GEN based on admission criteria. As such, these students represent some of the most vulnerable students at the university and need a lot of support and guidance in order to find their way to success. Some of this support is covered through the GEN program structure that provides a foundational engineering education and a wide range of technical electives. It is worth mentioning that a similar hands-on activity that uses robotic hands as a learning tool for 4th-year mechatronics engineering students was reported in [10]. The design experiment in [10] required knowledge about physiological signals such as

electromyography (EMG) waveforms and signal processing methods that transform the EMG waveform into a control signal later used to control the robot's movement. These tasks are realistic for 4th-year students since they would have learned this knowledge throughout their study years. However, our implementation is simplified to very basic control signals using a push button to control the movement of the hand. Our hypothesis is that first-year general engineering students will acquire more skills when learning is presented with enjoyable hands-on projects. To validate this hypothesis, we embarked on a study that divided the FED101 class into two groups: a control (17 students) and a treatment (37 students). All students were taught the same concepts, namely, basic circuit building and coding. Students in the control group did not use the robotic hand to test the circuits and codes they built. Instead, their experience was limited to building servo circuits and writing codes that can change the shaft's position of a servo motor. As for the treatment group, students tested their codes on servo motors that are embedded in the robotic hand and used to control the opening and closing of the hand's fingers. We compared the performance of the students in both groups to assess if this activity benefited the students. In order to assess the performance difference between the control and treatment group, we employed (1) quantitative metrics (such as mean, median, and standard deviation of their grades) and (2) a qualitative creativity metric adapted from CPAM [12].

The rest of the paper is organized as follows. In the section "Methodology and Implementation," we provide all the necessary information about the construction of the robotic hand and the implementation of this activity in a classroom setting. All codes, 3D models, and components used in building the hand are available in the GitHub repository in [13]. Furthermore, we present and assess the performance of students of both control and treatment groups in the "Data Collection and Performance Metrics" section, followed by our "Results and Discussion."

## **Methodology and Implementation**

In this section, we present step-by-step instructions for the construction of the robotic hand (Section 1) as well as a guideline to implement this project in a classroom setting (Section 2). All 3D models, electric components, and codes we employed in building and controlling the hand are available in the following GitHub repository in [13]

### *Section 1: Construction of the Robotic Hand*

The overall robotic hand design consists of two main parts, namely, the base unit (Figure 1) and the hand unit (Figure 2).

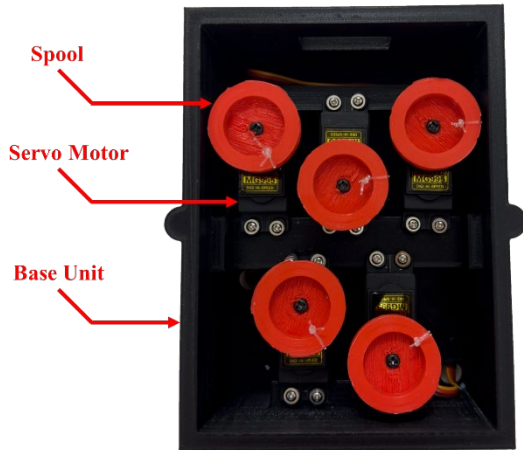

**Figure 1. The base unit houses servo motors with attached wire spools.**

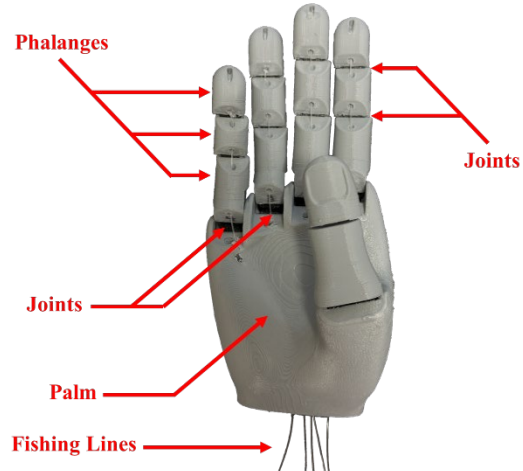

**Figure 2. The hand unit is comprised of phalanges, joints, and a palm. Fishing line runs through the fingers.**

Base unit: The base is employed as a platform that holds the hand and encloses the servo motors that control the opening and closing (extension and flexion) of individual fingers of the hand. The base model is available in [13]. The base encloses five high-torque MG995 servo motors, each controlling one finger of the hand. Additionally, we connect a spool to the shaft of the servo motor. A fishing line is used to connect the fingers to their corresponding spool. One end of the fishing line is wrapped around the spool, and the other end is connected to the finger. If the motor turns clockwise, the spool will turn clockwise, causing the fishing line to shorten, which will flex the finger. Alternatively, when the motor turns counterclockwise, the spool will turn counterclockwise causing the fishing line to lengthen which will extend the finger. Figure 3 is an illustration of the flexion/extension mechanism.

Hand unit: We used the open-source hand design provided in [14]. The hand model consists of fifteen individual parts, namely, a palm and fourteen phalanges making up the fingers. Additionally, fourteen joints are employed in each hand. Unlike the other parts of the hand that are 3D printed using Polylactic acid (PLA), joints are 3D printed using Thermoplastic Polyurethane (TPU). The flexible properties of TPU make it desirable in joint design since this will allow the fingers to flex and extend. The 3D models of the hand (palm, fingers, and joints) are available in [13], [14].

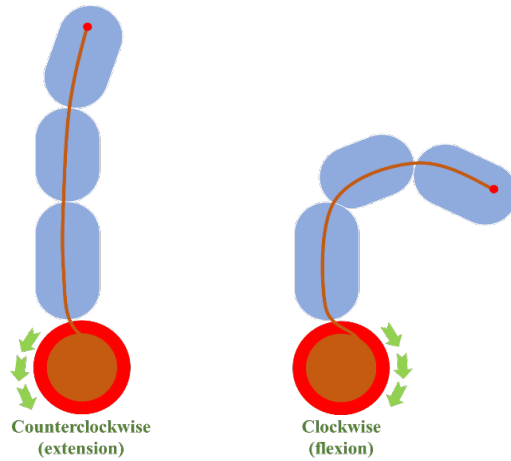

**Figure 3. Illustration of the flexion and extension mechanisms.**

Hand Control: Each individual finger is controlled by a servo motor. We employ an Arduino UNO to control the angle of the servo motor's shaft. By changing the angle, we can turn the spool clockwise (to flex the finger) and counterclockwise (to extend the finger). For simplicity, we selected two angles – one for extension and one for flexion. Students learned to control the finger's action using a push button used to toggle between the flexion and extension positions. The codes used for the hand control are available in [13]. Figure 4 shows a front-facing view of the robotic hand assembly.

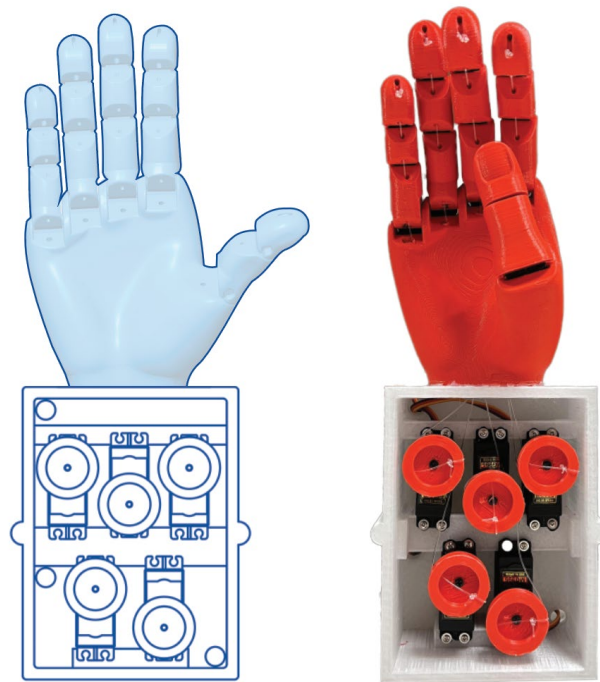

**Figure 4. Assembly of hand unit and base unit.**

## Section 2: Implementation of the Robotic Hand in a Classroom Setting

The main objective of this study was to investigate the benefits of using a fun and engaging hands-on activity in first-year engineering design classes. In order to assess the effectiveness of this activity, we divided the class into two groups, a control group and a treatment group. To prepare students (both in control and treatment groups) for this activity, we dedicated three laboratory periods in which we covered fundamental circuit building and Arduino coding. Both groups were given the same tasks, materials, and lab exercises and were graded following the same rubric. The only difference is that the control group did not use the robotic hand. Instead, the students used a single servo motor. Alternatively, students in the treatment group applied the coding and electric circuit-building skills to the robotic hand. Prior to coding and circuit building, students spent the first six weeks of the semester learning basic to intermediate-level 3D modeling using Creo Parametric.

We developed a hands-on activity that uses a push button to control the position of a servo motor with Arduino UNO. Students worked towards completing this activity over a span of two weeks.

Activate Servo: For this activity, students were taught fundamental coding skills (such as variables and if-else statements) as well as circuit building (such as how to connect a push button to Arduino). Additionally, the Arduino library “Servo.h” was introduced. Students were then provided with an Arduino script that uses a push button to toggle between two positions of the servo motor. The initial position values were arbitrary. For this activity, students were asked to run the code and set two positions for their servo motor (one position for when the button is pressed and another position for when the button is released). Table 1 below shows a graphic interpretation of the activity. Students in the treatment group were able to see the fingers of the hand curl as a result of their input.

**Table 1. Graphical illustration of Activate Servo activity for control and treatment groups.**

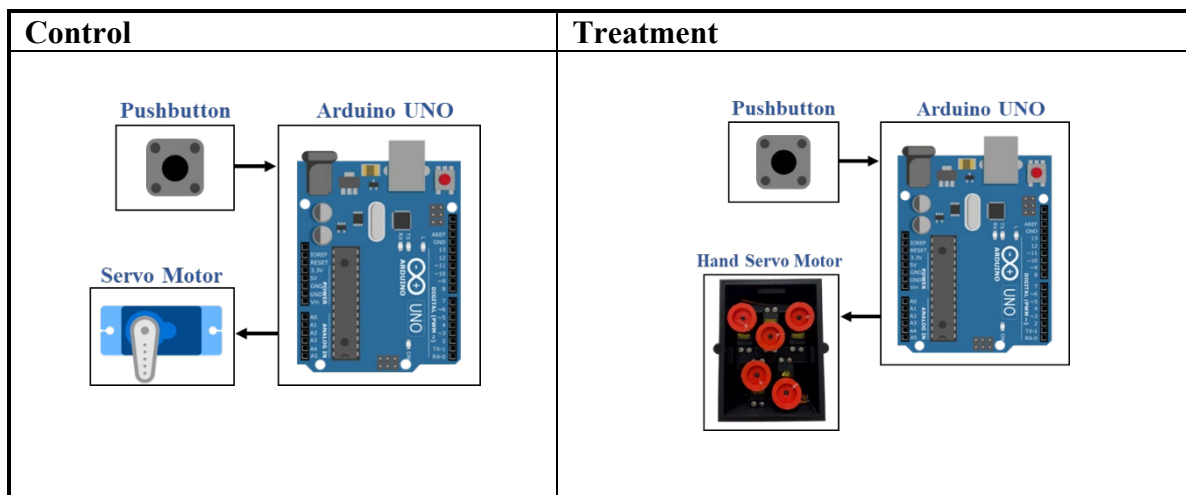

At the end of the semester, students were tasked to work on a final project wherein they were instructed to design and 3D print a mechatronic device from a list that was provided by the instructional team. The students had to pick one of the following projects: catapult, timer, gumball machine, dump truck, robotic arm, dancing robot, moving light, and safe box. For example, for the catapult projects, students were asked to come up with an innovative and original design that should be able to launch a candy following the push of a button.

### **Data Collection and Performance Metrics**

We recorded the grades of students from the control and treatment groups for the servo control activity as well as the final project. First, we provide a quantitative data analysis for both the control and treatment groups in order to flag any difference in performance between these groups. The quantitative metrics that we used are mean, median, and standard deviation.

In addition to the quantitative assessment, we provide a qualitative analysis that measures the level of creativity in the final project for the control and treatment groups. The metric used to measure creativity in this study is the variation of the Creative Product Analysis Matrix (CPAM) [15], [12]. This model scores characteristics of creativity in three categories: Resolution, Elaboration & Synthesis, and Novelty [15]. Resolution addresses the function of the project [12]. Elaboration & Synthesis describes the style of the design and the assembly of the project [12]. Novelty considers design features that are original and new ideas implemented in the project's development [12], [16]. To measure the creativity of a project, the CPAM metric can be used to score each characteristic of its creativity [12]. Similarly, our metric functions as a rubric for the facets of creativity. We used three categories, each with two sub-categories, scored on a scale from 1-10. The categories are summarized in Table 2.

**Table 2. Graphical illustration of the task of this activity for control and treatment groups.**

<b>Category</b>	<b>Sub-category</b>	<b>Definition</b>
Originality	Novelty	The project features a new implementation or display of an idea. The project is inventive,  1 = nothing new, 10 = new features
	Non-obviousness	The project includes features that surpass what is expected. The project includes features that other groups did not consider.  1 = obvious design, 10 = not obvious
Purpose	Functionality	The project functions as intended.  1 = fails to function, 10 = highly functional
	User-Friendliness	The intended function of the project is clear to the user.  1 = hard to understand, 10 = easy to understand
Synthesis	Organic	The project is pleasing to the eye. It features an ergonomic design for optimal UI/UX.  1 = not pleasing, 10 = easy and enjoyable to use
	Well-crafted	The project is manufactured with quality and designed well for assembly. The circuitry is integrated cleanly.  1 = messy project, 10 = highly presentable

Each factor is an important consideration in engineering design, and some projects tend to favor one category over another. In general, the creativity of projects can be compared using their score.

### **Results and Discussion**

In this section, we analyze the grades of the students in the control and treatment groups shown in Table 1. We employ both quantitative and qualitative metrics to assess the performance of students. The quantitative metrics are the mean, median, and standard deviation of the grades



obtained from the Activate Servo activity and the final project. The qualitative metric, shown in Table 5, is the creativity score obtained from the final project. Table 3 shows the total number of students used to calculate these performance metrics for both the control and the treatment groups. In this study, we exclude the students with a zero grade from our analysis. The number of students with a zero grade is shown in the last column of Table 3.

### Student Performance

The quantitative metrics are summarized in Table 4. We observe from Table 4 that the mean grade of the Activate Servo activity and final project of the control group is greater than that of the treatment group. The qualitative metric is summarized in Table 5. We observe from Table 5 that the average creativity of the control group is greater than that of the treatment group.

**Table 3. Analysis of the grades of the students in control and treatment groups.**

	Activity	Total number of students	Number of students with 0-grade
Control	Activate Servo	17	6
	Final project	17	2
	Creativity analysis	17	2
Treatment	Activate Servo	37	4
	Final project	37	0
	Creativity analysis	37	0

**Table 4. Mean, median, and standard deviation of control and treatment for Activity 1 and the final project (zero grades excluded).**

Group	Metric	Activate Servo	Final Project
Control	Mean	98	100
	Median	100	100
	Standard Deviation	6.32	0
Treatment	Mean	96.17	86.4
	Median	100	94
	Standard Deviation	16.9	18.35

Additionally, we ran pairwise two-sample Wilcoxon rank sum tests on the difference between the treatment and the control for (1) Activate Servo activity grades, (2) the final project grades, and (3) the creativity scores. We conclude the following:

- When testing the Activate Servo activity grades, there is no statistical significance between control and treatment group (p-value= 0.811).
- When testing for the final project grades, there is a statistical significance between control and treatment group (p-value<0.001).

- When testing for the creativity scores, there is no statistical significance between control and treatment group (p-value= 0.849).

**Table 5. Mean, median, and standard deviation of control and treatment groups' creativity metrics (zero grades excluded).**

Test Side	Mean	Median	Standard Deviation
Control	31.14	29	10.19
Treatment	29.6	29	12.12

### Creativity Assessment

In this section we present three sample projects that were picked to showcase different characteristics of creativity. Figure 5 shows the CAD assembly of a gumball machine, Figure 6 shows the CAD assembly of a smart safe, and Figure 7 shows the CAD assembly of a smart timer project.

#### Project 1: Gumball Machine

This project features a rotating ball dispensing design that we have never seen before. However, the design is not practical for assembly or circuit integration. It scores highly for novelty and non-obvious design, and it scores low for well-crafted and organic design.

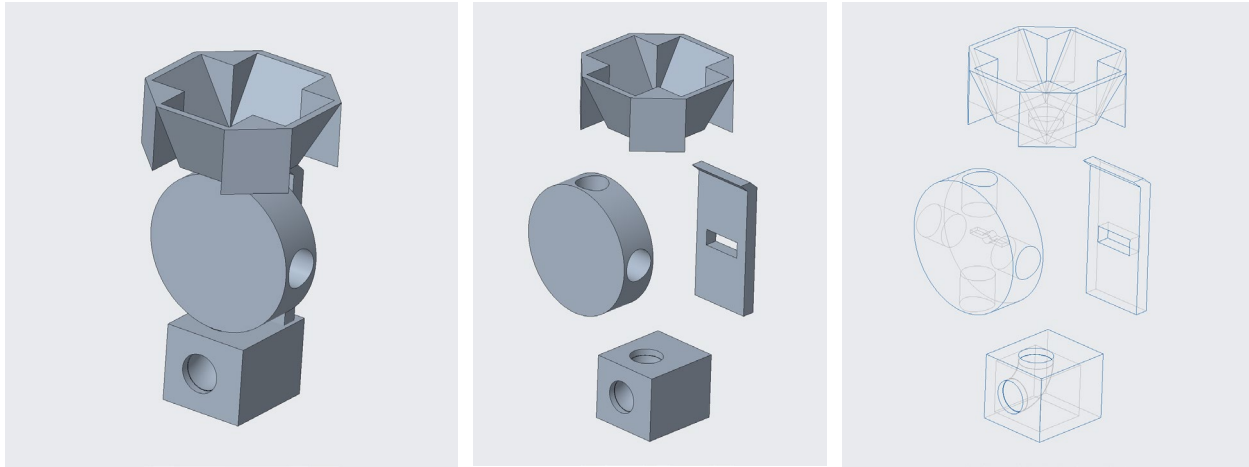

**Figure 5. 3D modeled assemblies of a gumball machine.**

### Project 2: Smart Safe

This design is standard for a smart safe. It scores highly for well-crafted (for hardware integration) and user interaction, and it scores low for originality.

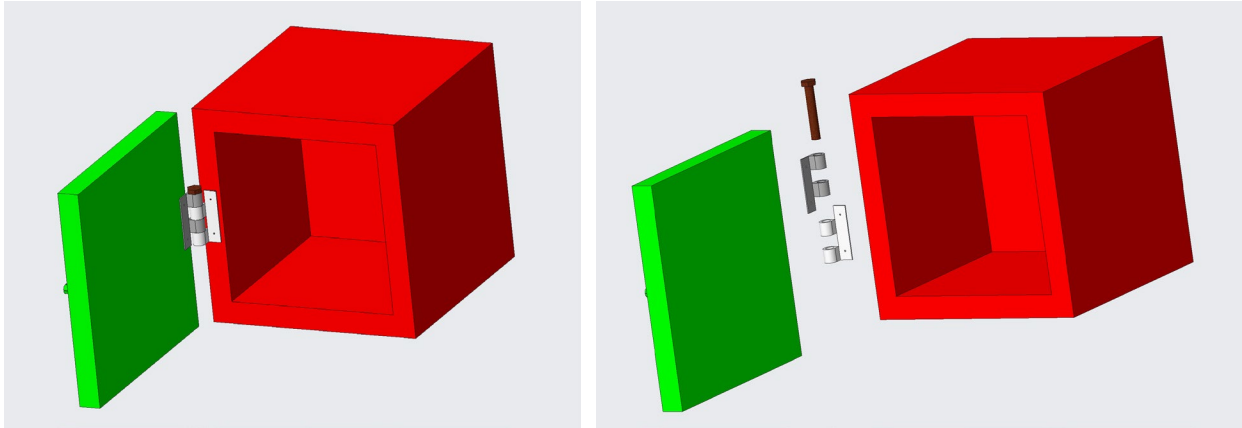

**Figure 6. 3D modeled assemblies of a smart safe.**

### Project 3: Smart Timer

This project features an original timer design with a fun tomato motif. This project scores highly for novelty, user experience, and organic design.

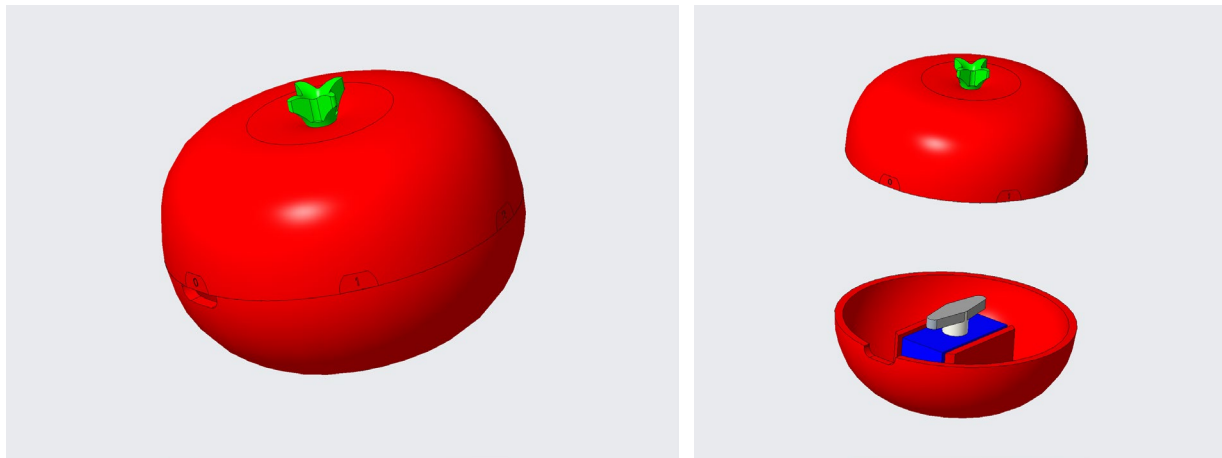

**Figure 7. 3D modeled assemblies of Tomato shaped smart timer.**

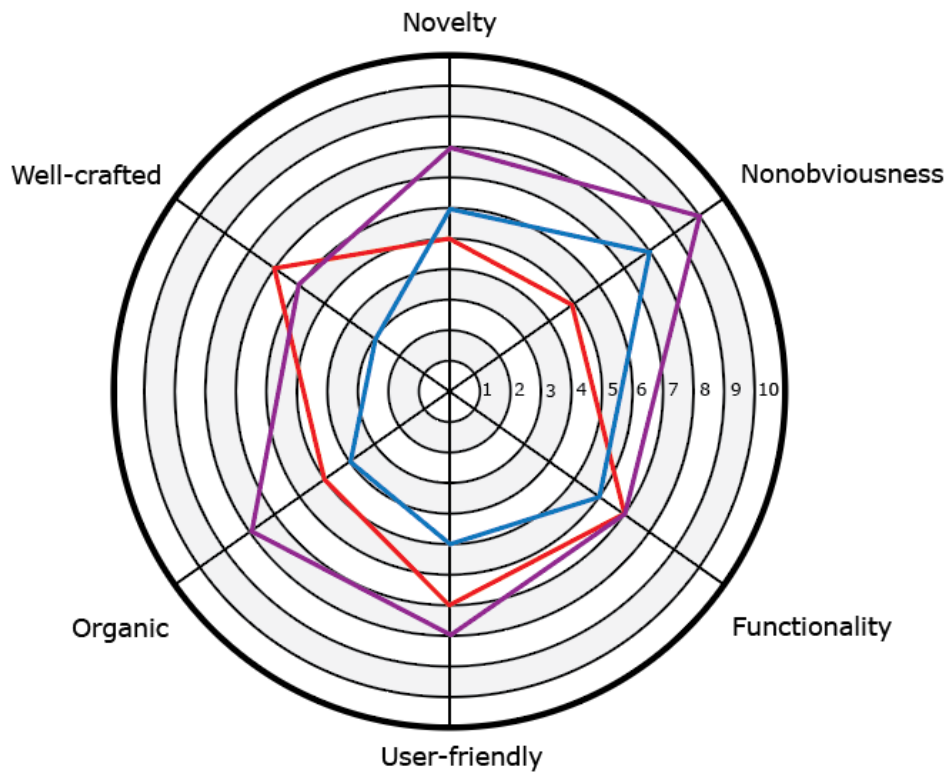

**Figure 8. Creativity radar chart for all three projects. Red: smart safe; Blue: gumball machine; Purple: smart timer.**

The radar chart in Figure 8 presents a visual comparison of the creativity score assigned to each of the three listed projects. The gumball machine project, represented in blue, leaned to the right because it is especially novel. The smart safe project, represented in red, leaned to the left because it is especially practical. The smart timer project, represented in purple, scored highly across the board.

### Qualitative Feedback

At the end of the course, feedback was also collected from the course evaluations run by the university. In addition to other Likert scale type questions, this survey features open-ended questions for the students to provide brief descriptive feedback about their experiences. The qualitative feedback questions on the survey were:

1. What are the best features of this course?
2. What aspects of the course would you want to see improved?

Students were encouraged to provide feedback during class time, ensuring a high level of participation. The treatment group (37 students in total) had 86.5% response rate as compared to 94.1% response rate for the control group (17 students in total). The feedback responses received were analyzed to identify recurring themes.

For the first question (what are the best features of the course?), three themes were identified:  
*Applied and hands-on* – Since the nature of the engineering field is very applied, it is important that students can get exposed to this aspect of it early on in their academic life.  
*Enjoyable and engaging* – Providing an enjoyable and engaging project, helps students keep motivated for the course and in general, for an engineering degree as well in the long run.  
*Exposure to engineering and engineering majors* – One of the goals of a first-year engineering design course is to provide students with an opportunity to explore what engineering is and its various majors, especially for our student population as a lot of them are still undecided on their major.

The comments received for this question were split into these three themes for both the treatment and control group and the results are summarized in the following Table 6. Both student populations seem to have similar feedback on the best aspects of the course except that the control population found their class to be more enjoyable and engaging. Since the small size of the two populations, not much could be concluded from these results.

**Table 6. Comparison of feedback received for Q1: what are the best features of the course?**

Themes	Treatment	Control
Applied and Hands-On	25%	23%
Enjoyable and engaging	28.6%	38.5%
Exposure to Engineering and Engineering Majors	46.5%	46.2%

For the second question (What aspects of the course would you want to see improved?), two themes were identified in the feedback received. They were for more hands-on activities and no improvement needed. No improvement needed theme is expected in such a survey. The urge for more hands-on activities can be explained by the presence of already existing hands-on projects and activities peaking students’ interest. The following Table 7 summarizes the results. The results seem similar, but again the small size of both populations makes it difficult to draw any impactful conclusions.

**Table 7: Comparison of feedback received for Q2: what aspects of the course would you want to see improved?**

Themes	Treatment	Control
More Hands-on Activities	22.2%	25%
No Improvement Needed	22.2%	33.3%

## Conclusion

In summary, this paper introduces a hands-on activity that uses a robotic hand to teach first-year students coding and circuit building skills. This concept was tested in a class of 54 first-year general engineering students. The class was divided into a control and a treatment group. The difference between the two groups is that the treatment group used the robotic hand to learn coding and circuit building whereas the control group did not use the robotic hand. We quantitatively assessed the performance of each group by comparing the group grades on the Activate Servo activity and the final project. Additionally, we created a creative score for the final project. When we compared the control group to the treatment group (grades and creativity score), there was no evidence that the treatment group's performance was better than the control group. Based on these results alone, and due to the small sample size, it is unclear if the use of a robotic hand directly impacted student performance. This gives good cause to repeat the experiment several more times before making a conclusive judgement.

## References

- [1] R. Felder, "Engineering Education: a Tale of two paradigms," *2nd. Int Conf Geotech. Eng. Educ.*, pp. 9–14, 2012, [Online]. Available: <http://www4.ncsu.edu/unity/lockers/users/f/felder/public/Papers/TwoParadigms.pdf>. [Accessed April 28, 2023].
- [2] C. A. Jara, F. A. Candelas, S. T. Puente, and F. Torres, "Hands-on experiences of undergraduate students in Automatics and Robotics using a virtual and remote laboratory," *Comput. Educ.*, vol. 57, no. 4, pp. 2451–2461, 2011, doi: 10.1016/j.compedu.2011.07.003. [Accessed April 28, 2023].
- [3] C. S. Cheah, "Factors contributing to the difficulties in teaching and learning of computer programming: A literature review," *Contemp. Educ. Technol.*, vol. 12, no. 2, pp. 1–14, 2020, doi: 10.30935/cedtech/8247.
- [4] B. Bettin, M. Jarvie-Eggart, K. S. Steelman, and C. Wallace, "Preparing First-Year Engineering Students to Think About Code: A Guided Inquiry Approach," *IEEE Trans. Educ.*, vol. 65, no. 3, pp. 309–319, 2022, doi: 10.1109/TE.2021.3140051. [Accessed April 28, 2023].
- [5] J. M. Gómez-De-Gabriel, A. Mandow, J. Fernández-Lozano, and A. J. García-Cerezo, "Using LEGO NXT mobile robots with Lab VIEW for undergraduate courses on mechatronics," *IEEE Trans. Educ.*, vol. 54, no. 1, pp. 41–47, 2011, doi: 10.1109/TE.2010.2043359. [Accessed April 28, 2023].
- [6] S. Cevik Onar, A. Ustundag, Ç. Kadaifci, and B. Oztaysi, "The Changing Role of Engineering Education in Industry 4.0 Era," in *Industry 4.0: Managing The Digital Transformation*, Cham: Springer International Publishing, 2018, pp. 137–151. doi: 10.1007/978-3-319-57870-5\_8. [Accessed April 28, 2023].
- [7] B. E. Dunne, A. J. Blauch, and A. Sterian, "The Case for Computer Programming Instruction for All Engineering Disciplines," 2005. doi:10.18260/1-2—15520. [Accessed April 28, 2023].
- [8] A. Luxton-Reilly, "Learning to program is easy," *Annu. Conf. Innov. Technol. Comput. Sci. Educ. ITiCSE*, vol. 11-13-July-2016, pp. 284–289, 2016, doi:

- 10.1145/2899415.2899432. [Accessed April 28, 2023].
- [9] A. Robins, J. Rountree, and N. Rountree, "Learning and Teaching Programming: A Review and Discussion," *Comput. Sci. Educ.*, vol. 13, no. 2, pp. 137–172, 2003, doi: 10.1076/csed.13.2.137.14200. [Accessed April 28, 2023].
- [10] I. Garcia, E. Guzmán-Ramírez, M. Arias-Montiel, and E. Lugo-González, "Introducing a robotic hand to support lecture-based courses on mechatronics systems design at the undergraduate level," *Comput. Appl. Eng. Educ.*, vol. 28, no. 6, pp. 1612–1627, 2020, doi: 10.1002/cae.22336. [Accessed April 28, 2023].
- [11] New Jersey Institute of Technology, "B.S. General Engineering." *University Catalog 2022-2023*. Access: <https://catalog.njit.edu/undergraduate/newark-college-engineering/interdisciplinary-engineering-science/bs/>. [Accessed April 28, 2023].
- [12] S. P. Besemer and K. O'Quin, "Confirming the three-factor creative product analysis matrix model in an American sample." *Creativity Research Journal*, vol. 12, no. 4, pp. 287-296. doi: 10.1207/s15326934crj1204\_6. [Accessed April 28, 2023].
- [13] J. Morlock, Robotic Hand Project for Engineering Education GitHub Repository. Available online: <https://github.com/JasonMorlock/Robotic-Hand-Project-for-Engineering-Education.git>. [Accessed April 30, 2023].
- [14] S. Wood, "Flexy Hand," *Ultimaker Thingiverse*, 2014. Available online: <https://www.thingiverse.com/thing:242639>. [Accessed April 28, 2023].
- [15] S. P. Besemer, "Creative product analysis matrix: testing the model structure and a comparison among products--three novel chairs." *Creativity Research Journal*, vol. 11, no. 4, pp. 333-346. doi: 10.1207/s15326934crj1104\_7. [Accessed April 28, 2023].
- [16] B. Lopez-Mesa and R. Vidal, "Novelty metrics in engineering design experiments." *In DS 36: Proceedings DESIGN 2006, the 9th International Design Conference, Dubrovnik, Croatia*, pp. 557-564. Access: <https://www.designsociety.org/publication/19047/NOVELTY+METRICS+IN+ENGINEERING+DESIGN+EXPERIMENTS>. [Accessed April 28, 2023].