

## Using Capstone PBL to Demonstrate Achievement of ABET Outcomes

### Dr. Maher Shehadi, Purdue University at West Lafayette (PPI)

Dr. Shehadi is an Associate Professor of Mechanical Engineering Technology (MET) in the School of Engineering Technology at Purdue University. His academic experiences have focused on learning and discovery in areas related to HVAC, indoor air quality, human thermal comfort, and energy conservation. While working with industry, he oversaw maintenance and management programs for various facilities including industrial plants, high rise residential and commercial buildings, energy audits and condition surveys for various mechanical and electrical and systems. He has conducted several projects to reduce carbon dioxide and other building emission impacts by evaluating and improving the energy practices through the integration of sustainable systems with existing systems. His current research focuses on engaging and educating students in sustainable and green buildings' design and energy conservation. He is currently investigating various ways to reduce energy consumption in office buildings.

# Using Capstone PBL to Demonstrate Achievement of ABET Outcomes

## *Abstract*

Interactive learning has been proven to increase students' retention, interests, way of thinking and job placement. Different methods are followed to achieve interactive learning environments in classroom including group assignments, in-class discussion or online threaded discussions, small projects and semester or year-long projects. Teachers and academic institutions face many challenges when implementing such methods in different courses at different levels. On one hand, challenges arise in securing funding, to mentoring, to identifying industrial partners and selecting proper projects. On the other hand, meeting college learning outcomes and ABET Student Outcomes when applying such tools in classes can pose real challenges if projects and activities are not properly designed to address each outcome. Capstone projects performed by senior year students offer a rich environment to apply concepts where students may apply concepts and knowledge gained throughout their college experience.

This paper examines project-based learning (PBL) implementation in a capstone project course sequence in the School of Engineering Technology at Purdue University. The course structure is designed to motivate students and engage them throughout a two-semester long project. Various sources were identified to select proper topics for the different teams. These sources include partners from industry, community foundations, local authorities and companies. Other sources could be research topics with professors in the same institute or other research laboratories. The projects are designed with six milestone deliverables (called "Gates") throughout the two-semester course. Key elements include high level educational goals for capstone including brainstorming, a marketing survey, design specifications, system development and testing.

The design and implementation of the projects focus on learning processes where students can apply knowledge and techniques, design systems, improve written and oral communication skills while working in a team-oriented environment. These skills are used to demonstrate achievement of ABET Student Outcomes using rubrics designed to assess each Gate. This paper presents the techniques used to evaluate and assess the ABET Student Outcomes using capstone projects.

## *Introduction*

The higher education learning processes and needs have been changing to produce competent practitioners who will be prepared for the multifaceted challenges of current technological advancements.

Today's real-world problems are more global and typically are not confined to a single discipline. The knowledge needed by engineering or engineering technology graduates joining the workforce comes from different domains and disciplines. According to a Purdue University survey of employers in 2013, skills and competencies that employers are seeking from recent graduates include: innovation as a priority, followed by problem solving in diverse settings, critical thinking, and complex problem solving [1]. The survey revealed that innovation, critical thinking, and complex problem solving are becoming more important for employers. To meet these new challenges, active learning methods provide a rich environment with the many ways that it can be offered such as: design projects, technology driven homework assignments, classroom exercises, working problems in small groups, guided and facilitated discussions, online quizzes, online threaded discussions, students presenting new material to the rest of the class, discussion-based learning, and plant tours.

Wlodkowski [2] indicated that analyzing and studying real life problems are essential components of any problem-based learning (PBL) environment. These motivate critical thinking, collaboration, and professional skills. Weber [3] indicated that it is important for PBL to have defined rubrics for success in order to meet educational goals. It is important to define achievable and reasonable rubrics that the students can understand and achieve successfully.

The capstone course in the School of Engineering Technology, which is in the Purdue Polytechnic Institute at Purdue University, is offered over two academic semesters. The needed skills to define, design and develop engineering technology solutions are introduced and developed. Planning and designing alternatives that meet cost, performance, and user-interface goals are emphasized while considering different design approaches. In addition, project planning, scheduling, and management techniques are studied. Teamwork, global and societal concerns, and professional ethics are integrated into course projects.

### ***Course Learning Objectives***

The following are the course learning objectives as defined by the college for the capstone course:

- Form a formal project proposal, create a functional prototype to solve the given problem.
- Utilize a software scheduling package to plan and track the progress of a project.
- Weigh design alternatives for customer requirements, efficiency, reliability, and cost.
- Formulate and apply formal test procedures to the developed prototype.
- Analyze the data acquired during testing of the prototype.
- Present the prototype design orally to a specific audience.
- Write a technical report including conclusions and recommendations for further work.

### ***Course Goals***

This course emphasizes aspects of “learning by doing” in a team activity within a semi-structured format. Structure is provided in the form of regular progress sessions with the instructor, assigned design activities, and adherence to implementing the features of the project as defined by the student with the instructor's overview. Independent activity is encouraged in the form of open laboratories and the keeping of records as self-directed entries in a technical journal.

Through the design, building and testing process, the student should learn:

- Strategies for the creation and development of ideas for projects
- Importance of recognizing problems and problem definition
- Writing of project descriptions and specifications
- Maintaining a technical journal
- Sources of parts and procurement methods
- Examples and use of project schedules, time charts or Gantt chart
- Team dynamics and how to interact on a project team
- Sources of information and reading manufacturer's specifications
- Formal presentation of technical material using computer presentations
- Designing and building a significant technical project
- Problem solving of technical, logistic and budget aspects of the project
- Collaboration and consultation with instructor, faculty, outside experts and peers
- Evaluation, testing, and demonstration of the operation of a technical project
- Documentation of a project in the form of progress reports and final report

**Course Structure and Assessment**

The methods proposed in the two-semester capstone projects target involving the senior students in solving real world problem which could be an ongoing research and production issue where the students would explore and innovate during the project implementation.

The methods aimed to split the design and implementation of the project between the two semesters. Prototype design and conceptual analysis were conducted over the first semester, whereas system implementation, testing and product improvement were done during the second semester as shown in Figure 1. Table 1 shows the different milestones or gates to be accomplished. Gate 1 through Gate 3 were done during the first semester, whereas Gate 4 through Gate 6 were done during the second semester. Different goals and tasks were required between the different gates including market analysis, decision matrix, product specifications, and testing plan. These are shown in Figure 1.

**Table 1. Scheduled Gates**

Gate 1	Project Proposals
Gate 2	Conceptual Design
Gate 3	Prototype Demonstration
Gate 4	Critical Design Review
Gate 5	Project Presentations
Gate 6	Final Report

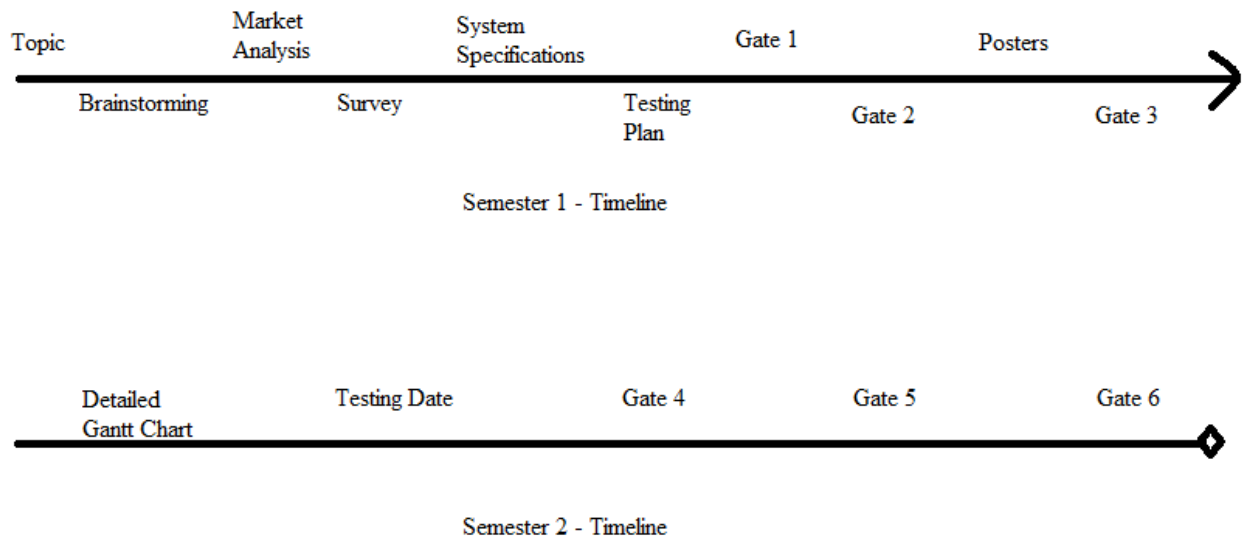

**Figure 1. Proposed capstone timelines**

During the first semester, the students are allowed to form their own teams to match self-crossing interests and then a project topic is identified. The typical practice is to source projects from industry partners who provide a list of different topics and problems to be addressed. Other sources for projects are from students who identify a current issue on their own or through their employer. Following the team formation and topic selection, approval by the course instructor, brainstorming and market analysis are done to search the market for existing and viable non-existing solutions. The non-existing solutions help the teams identify issues in existing designs and explore areas for improvement. Following the market analysis, the teams prepare a survey and identify project stakeholders to assess marketability and desired features for their project/product. For example, when designing a pet cage emergency lock, the people who were asked to participate should have/had a pet because they would provide more knowledgeable and honest responses. Similarly, when surveying for a new product related to improving solar and electric vehicles, the teams would target users who are interested in such products. After surveying and collecting different opinions, the teams analyze the data, identify specifications, build a decision matrix and begin the system overview using a block diagram. The main question that the teams should ask themselves when determining system needs and specifications is the following:

*“What key measures will indicate success for the project?”*

Each specification identified would serve as a performance indicator upon which the teams need to build a testing plan and assessment. The testing plan and assessment should identify benchmarks to determine if the specification is met for each performance indicators.

After working on these preliminary tasks, the teams submit a formal project proposal and present it to the course instructor and other teams in the course. This milestone represents Gate 1 with rubrics shown in Table 2 including preliminary information to get the project initiated such as problem definition, market analysis and existing solutions. In addition to this, the instructor evaluates the team’s written communication skills and visuals used in both the proposal report and the presentation. These rubrics along with the grading scale and weights applied to the different performance indicators are shown in Table 2. The performance indicators in all gates are assessed on a scale of 0-4 with: 0-1 being at the deficient level, 2-2.5 at the developing level, 3 at the emerging level and above 3 at the proficient levels. These levels are used for ABET outcomes assessment.

**Table 2.** Gate 1 Rubric (The highlighted rubrics are used to assess ABET outcome 3.1 as shown in the ABET assessment section)

Name(s):		Proficient (4)	(3.5)	Emerging (3)	(2.5)	Developing (2)	(1)	Deficient (0)	Score (0-4)	x Weighting	Category Points	NEW ABET
Project Title:												
<b>Problem Definition</b>	The problem is clearly stated, the background and theory understood. Drawings and pictures included as appropriate to explain problem.								##	8	##	3.1 PI1
<b>Prior Art</b>	Sufficient research has been done to seek existing solutions and the strengths and weaknesses of those solutions have been defined.								##	5	##	3.1 PI1
<b>Preliminary Solution/ Challenges and Constraints</b>	A realistic solution for the problem has been presented and the challenges and other constraints are defined.								##	5	##	3.1 PI1
<b>Market Analysis</b>	The report discusses the demographics of the target user and potential sales. A survey of potential users is included								##	5	##	
<b>Written Communication</b>	Document is well organized, grammatically correct, sentence structure is clear, and there are no misspelling/wrong word or run on sentences.								##	5	##	
<b>Visuals</b>	Document uses visual and graphical techniques to present ideas. Figures are properly titled and annotated. Tables are properly titled. Units are used properly. Flow charts and block diagrams are easy to follow.								##	5	##	
<b>References and Acknowledgement of Sources</b>	Sources of materials (pictures, specifications, articles) properly identified and acknowledged								##	4.5	##	
<b>COMMENTS:</b>										Total (150 max)	##	Average Level for ABET:

Following Gate 1, the students start articulating the conceptual design for their projects and present it four weeks after presenting the proposal. These four weeks give the teams enough time to formulate an idea of tasks needed, the milestones identification, material needed, estimated time to complete the scheduled tasks and the associated costs. The rubrics for the conceptual design presented in Gate 2 are shown in Table 3.

**Table 3.** Gate 2 Rubric (The highlighted rubrics are used to assess ABET outcome 3.1 as shown in ABET Assessment section)

Name(s):		Proficient (4)	(3.5)	Emerging (3)	(2.5)	Developing (2)	(1)	Deficient (0)	Score (0-4)	x Weighting	Category Points	ABET
Project Title:												
<b>Problem Definition</b>	The problem is clearly stated, the background and theory understood. Drawings and pictures included as appropriate to explain problem.								#DIV/0!	3	###	
<b>Decision Matrix</b>	Multiple options for solving the problem are considered and benefits and weaknesses are evaluated. A decision matrix with weighting factors justified is presented and design selection supported.								#DIV/0!	10	###	3.1 - PI1
<b>Initial Design Concept</b>	An initial design is presented based upon information from prior art, decision matrix and market survey input.								#DIV/0!	8	###	3.1 - PI1
<b>Work Breakdown</b>	The Gantt chart shows appropriate tasks organization, maintains options and foresees interaction including testing. The Gantt chart should be completed through both semesters.								#DIV/0!	8	###	
<b>Oral Communication</b>	Document is well organized, grammatically correct, sentence structure is clear, and there are no misspelling/wrong word or run on sentences.								#DIV/0!	8	###	
<b>Visuals</b>	Document uses visual and graphical techniques to present ideas. Figures are properly titled and annotated. Tables are properly titled. Units are used properly. Flow charts and block diagrams are easy to follow.								#DIV/0!	8	###	
<b>References and Acknowledgement of Sources</b>	Sources of materials (pictures, specifications, articles) properly identified and acknowledged								#DIV/0!	7	###	
<b>COMMENTS:</b>										Total (200 max)	###	Average Level for ABET:

Before ending semester 1 with a prototype demonstration in Gate 3, as shown on the timeline in Figure 1, the students prepare a draft poster of their project. In Gate 3, not all performance indicators must be fulfilled and the prototypes do not necessarily have to be in full working conditions. Instead, the teams are asked to demonstrate that their concept works and that they are qualified to continue to the next semester to implement the concepts. The rubrics for Gate 3 are shown in Table 4. As shown, the work done by the teams at this stage is based on whether the prototype functions or demonstrates that the concept is feasible by examining the identified specifications. The teams' effectiveness working in teams, task organization and work break down along with presentation skills are all assessed as part of Gate 3 end of the first semester.

**Table 4.** Gate 3 Rubric (The highlighted rubrics are used to assess ABET outcome 3.1 as shown in ABET Assessment section)

Name(s):		Proficient (4)	(3.5)	Emerging (3)	(2.5)	Developing (2)	(1)	Deficient (0)	Score (0-4)	x Weighting	Category Points	ABET
Project Title:												
<b>Prototype Functions</b>	Although there may be some minor issues, the prototype functions and there are no major hurdles in the way.								##	20	##	3.1 - PI2
<b>Specifications are Met</b>	The prototype meets the primary design specifications.								##	10	##	3.1- PI2
<b>Task Organization</b>	The student has a clear plan for what tasks need to be completed in order to finish the project by the deadline. Work breakdown structure is detailed and milestones appropriate enough to control project.								##	10	##	
<b>Oral Communication</b>	The student uses proper grammar in the demonstration of the prototype. The presentation is organized and the student appears confident in their knowledge of the subject. Any questions posed are well answered.								##	10	##	
<b>COMMENTS:</b>										Total (200 max)	##	Average Level for ABET:

Teams begin their second semester by presenting a Gantt chart, identifying gaps and tasks that were not completed in the first semester and projecting new time frame to meet the current semester deadlines and milestones. After submitting a detailed project schedule, the teams continue working on designing and testing the specifications before submitting their draft work in Gate 4 (at week 10 of the second semester). The rubric for Gate 4 are shown in Table 5. The teams are assessed by looking at the final system detailed design, their testing plans, the bill of materials and evaluating their presentation skills. The students then receive feedback to add final modifications and improvements to their projects before presenting the final products/projects in Gate 5 (Rubric shown in Table 6).



**Table 5. Gate 4 Rubric (Critical Design Review)**

Student Name(s):		Proficient (4)	(3.5)	Emerging (3)	(2.5)	Developing (2)	(1)	Deficient (0)	Score (0-4)	x Weighting	Category Points	ABET
Project Title:												
System Design	The system configuration, interconnects and interfaces are fully defined and understood.*								##	5	##	
Detailed Design	Design package is 100% complete and includes mechanical drawings with dimensions, schematics, PCB's designed, and software outlined.*								##	5	##	3.1 - P11
Test Plan	Testing of all critical performance parameters are defined, as are plans for ergonomic considerations (where applicable).								##	5	##	3.1 - P11
Bill of Materials	A complete bill of materials is presented.								##	5	##	
Oral Communication	The student uses proper grammar in the demonstration of the prototype. The presentation is organized and the student appears confident in their knowledge of the subject. Any questions posed are well answered.								##	5	##	
COMMENTS:										Total (100 max)	##	Average Level for ABET:

**Table 6. Gate 5 Rubric (Project Presentations)**

Name(s):		Proficient (4)	(3.5)	Emerging (3)	(2.5)	Developing (2)	(1)	Deficient (0)	Score (0-4)	x Weighting	Category Points	ABET Outcomes
Project Title:												
Technical Content	<ul style="list-style-type: none"> <li>Did the students apply and understand technical knowledge at the baccalaureate level in order to complete the project?</li> <li>Was the project at a sophistication level appropriate to a program graduate?</li> </ul>								##	10	##	3.3ORAL P14
Lifelong Learning	<ul style="list-style-type: none"> <li>Did the student demonstrate learning beyond what is covered by the curriculum?</li> <li>Were novel technologies or techniques used?</li> <li>Was there evidence that sufficient research was done to affect the solution?</li> </ul>								##	5	##	
Operation	<ul style="list-style-type: none"> <li>Considering economic constraints, does the project function as intended?</li> <li>Did it meet the original specifications?</li> </ul>								##	10	##	3.2 P11
Testing	<ul style="list-style-type: none"> <li>Did the student provide data demonstrating that the project met (or failed to meet) specifications?</li> <li>Where appropriate, were simulations performed to confirm the design?</li> <li>Where appropriate, was the project calibrated against a known standard?</li> </ul>								##	10	##	
Project Appearance	<ul style="list-style-type: none"> <li>Were ergonomics considered in the design?</li> <li>Are controls labeled appropriately?</li> <li>Is the prototype safe to use and robust?</li> <li>For ECET were printed circuit boards used?</li> </ul>								##	5	##	
Oral Communication	<ul style="list-style-type: none"> <li>Was the presentation organized and clear?</li> <li>Did the student use proper grammar and spelling?</li> <li>Was the student confident in their knowledge of the subject?</li> <li>Were questions fielded in an appropriate way?</li> <li>Was the presenter properly dressed (business casual or better) for a formal presentation?</li> </ul>								##	5	##	3.3ORAL: P12 & P13
Graphical Communication	<ul style="list-style-type: none"> <li>Were all visual aids clear?</li> <li>Were all figures graphs properly labeled and titled?</li> <li>Did the presenter use appropriate units on quantities?</li> </ul>								##	5	##	3.3ORAL: P14 & P15
COMMENTS:										Total (200 max)	##	3.3ORAL P11

Gate 6 is the final milestone for the capstone projects and it represents the final document or report submitted by the teams. The teams and the projects are graded based on the technical content, the overall structure and organization of the report, the grammar and spelling, visuals and the transition from one section to another. The organization and overall structure of the report contribute to 10%; the technical content, drawings, descriptions, and necessary data to support the functionality of the product contribute to 60%; and lastly, the grammar and spelling of the whole document contribute to 30% of the total grade of Gate 6.

### ***Project Example***

In this section, a project for designing and fabricating a “Safety Squat Bar Attachment” [4] is presented showing the different stages that were followed during this Project Based Learning course done as a capstone. Designing a new safety squat bar attachment was of interest to one of the team members and the team decided to work on it as their capstone project. The safety squat bar is a piece of equipment to use for resistance training and is typically a thick cambered barbell with front facing handles as shown in Figure 2.

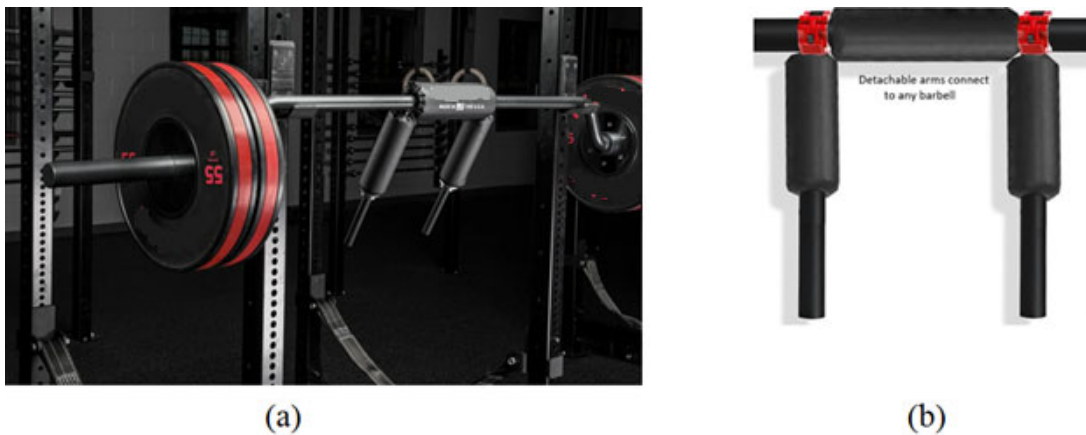

**Figure 2.** Squat bar example (a) attached (b) standing alone showing different components [4]

The team started the project by analyzing products available in the market and surveying interested people to determine the specifications of such a product.

### ***Market Analysis***

Different solutions were found during the market analysis as shown in Figure 3. The team identified the advantages and disadvantages of each solution and continued to shape the needs and performance indicators for the success of the product.



(a)



(b)



(c)

**Figure 3.** Different solutions found during market analysis [4]

*Survey*

After completing the market analysis and research, the team composed a questionnaire and surveyed interested consumers. The responses are shown in Table 7.

**Table 7.** Survey used in the project example (squat bar)

Question	Answer
Have you ever used a Safety Squat Bar?	Yes (×16)
If you have, what purpose did it serve?	Better quad activation, Variability, Comfort, Squat Variations, Good mornings, Allowed better posture due to tight chest, Injured shoulder unable to grip bar correctly, Less shoulder stress
Would this product serve this purpose?	Yes (×4)
Would you prefer that the attachment freely rotates or is in a fixed position?	Most answers say fixed, some rotate, others do not care as long as it is stable
What do you like most about this product?	Price, Detachable, Easy to store, Ability to adjust from person to person, Portability, Ease of use
What do you like least about this product?	Concept design, Lack of bar camber, Possible stability issues with this prototype
If this product were available, would you be interested in purchasing one?	Yes (×4)
How would you compare this product to its alternative; inferior, superior, equal?	Mixed Answers

### Specifications

Based on what was shown in Figure 2 (a) & (b), Figure 3 and Table 7, the system specifications were determined and are presented in Table 8.

**Table 8.** Project example system specifications

System Specifications
The product can be disassembled to fit in any gym bag
The product is affordable
The product is resistant to corrosion
The product is black to hide blemishes
The pad upholstery is hydrophobic & resistant to wear & tear
The handles are in a fixed position once applied to the barbell

The following couple sections shows the progress of the project throughout the different gates discussed earlier.

### Gate 1 – Proposal

#### Block Diagram

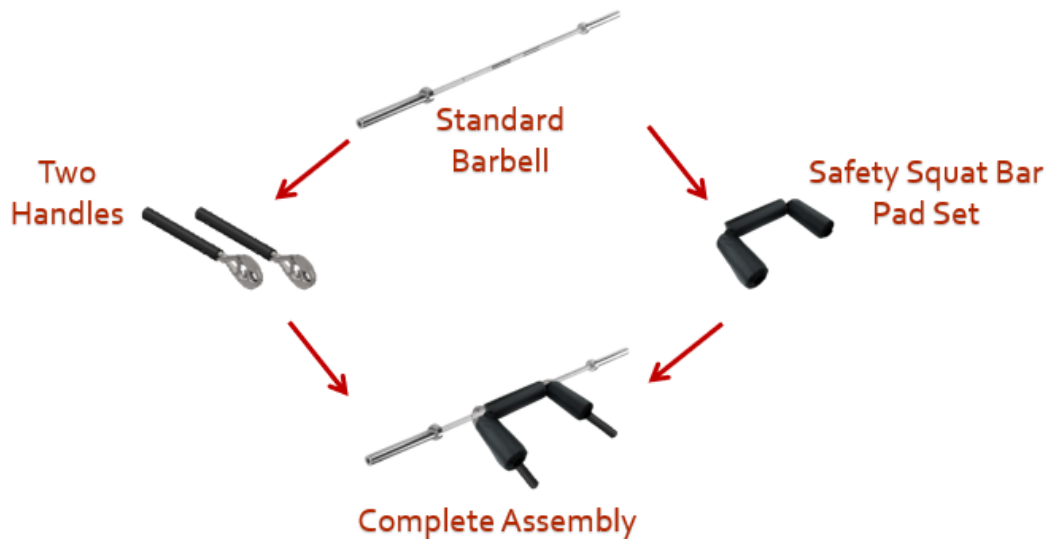

### Gate 2 – Conceptual Design (Shown in Figure 4)

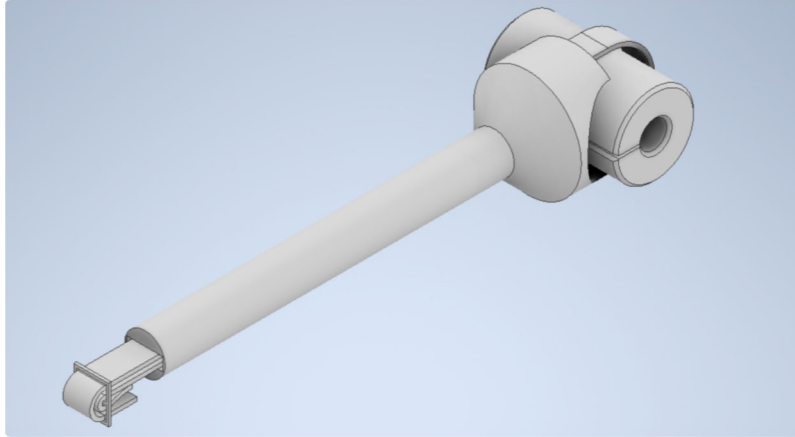

**Figure 4.** Conceptual design [4]

*Gate 3 – Prototype Demonstration (Figure 5)*

The team built a PVC prototype to test the functionality of the product and to decide on any further changes before the end of the first semester and before starting the critical design phase in semester 2.



**Figure 5.** Prototype [4]

*Gate 4 – Critical Design Review*

Some changes were recommended during the critical design phase and the modified design is shown in Figure 6. The final product design was drawn in a CAD software as shown in Figure 7 and the different components were 3D printed using as shown in Figure 8. The 3D printed version helped identify major failure and any required changes before sending for final production.

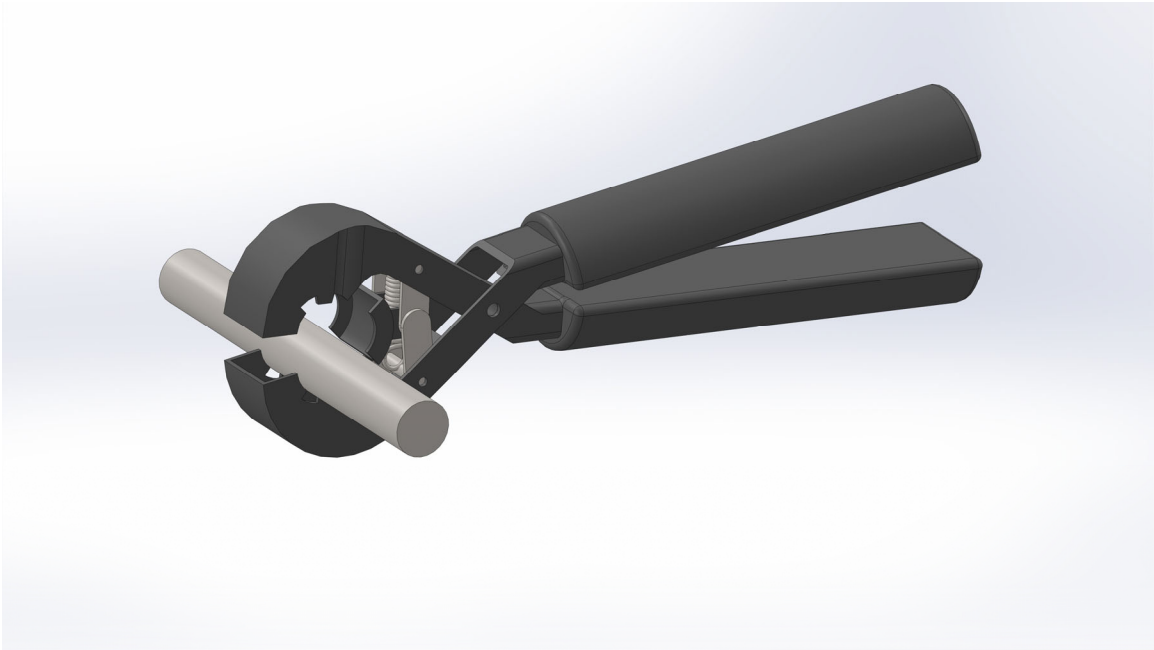

**Figure 6.** Critical design phase [4]

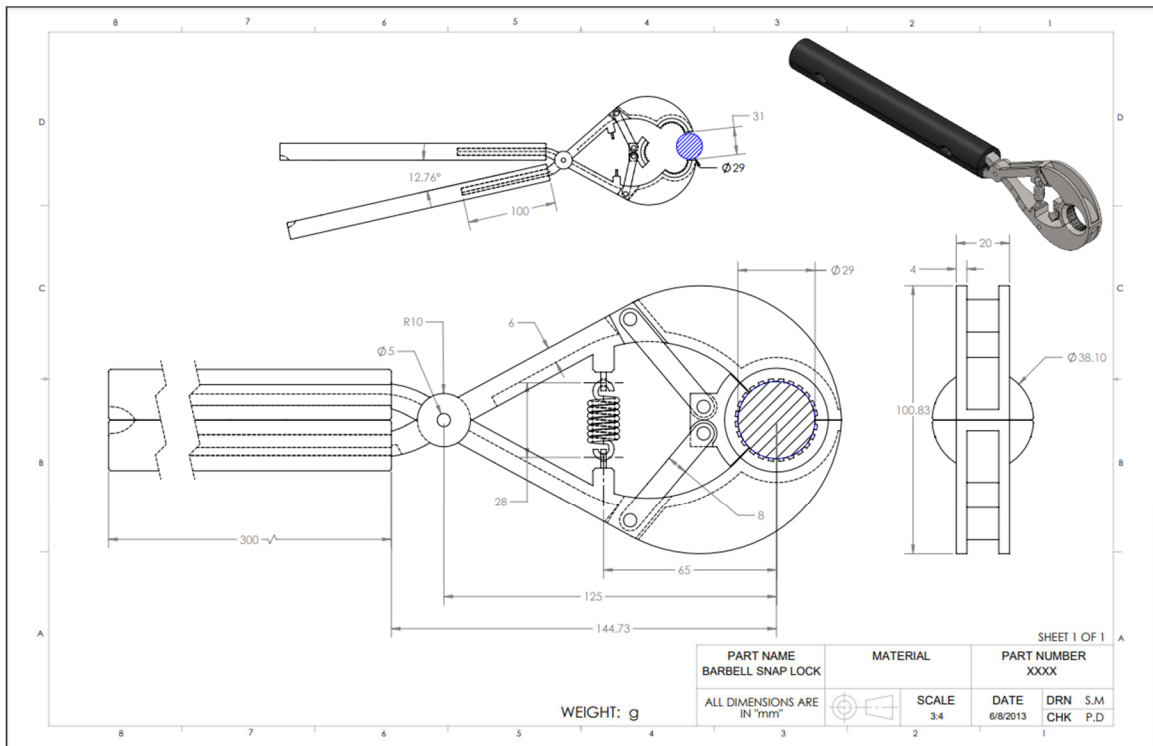

**Figure 7.** CAD drawing for showing modifications done to the critical design phase [4]

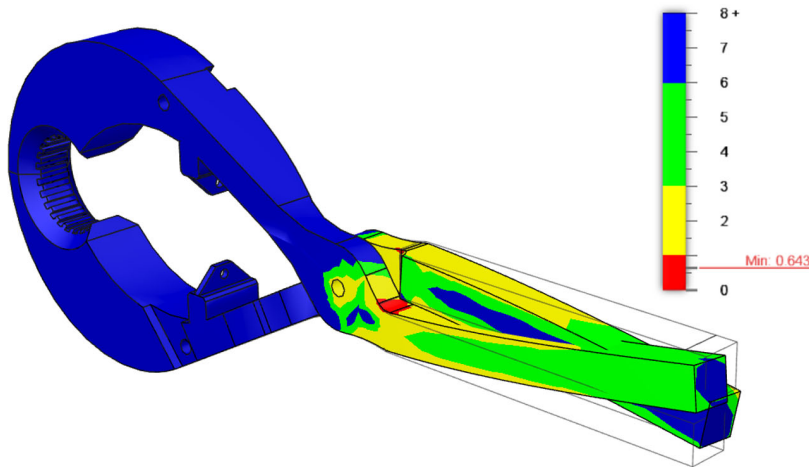



**Figure 8.** 3D printed product to test the functionality of the final design before sending for final production [4]

*Gate 5 – Final Project Presentation*

Before finalizing the product, force and stress analyses were performed for each part in the assembly as shown in Figure 9. These analyses resulted in some additional modifications; the final product is shown in Figure 10.



**Figure 9.** Stress and force analysis [4]



**Figure 10.** Final product [4]

### **ABET Learning Outcomes**

There are many skills and outcomes that meet the ABET Student Outcomes using PBL technique for the capstone projects. As shown earlier in the project example, the students demonstrated concept selection and applying, tested and analyzed systems, designed and documented their analysis, and satisfied the requirements for other outcomes as shown in Table 9. Table 9 shows the general ABET Student Outcomes, the performance indicators used that defined success criteria, and the assessment methods used such as presentations, calculations, reports, etc.



**Table 9.** ABET Student Outcomes and assessment criteria used

ABET Outcome		Performance Indicator #	Assessment Methods
3.1	<b>An ability to select and apply the knowledge, techniques, skills, and modern tools of the discipline to broadly-defined engineering technology activities</b>		
	<i>Select appropriate concepts, techniques, skills and modern tools of the discipline to participate in broadly-defined discipline specific activities</i>	PI-1	Gate 1 - Problem Definition Gate 1 - Prior Art Gate 1 - Preliminary solution Gate 2 - Initial Design Concept
	<i>Applies appropriate concepts, techniques, skills, and modern tools fo the discipline to broadly-defined discipline activities</i>	PI-2	Gate 3 - Prototype Function Gate 3 - Specifications Gate 4 - Test Plan
3.2	<b>An ability to design systems, components, or processes for broadly-defined engineering technology problems appropriate to the discipline</b>		
	<i>Awareness and understanding of a broadly defined technological problem related to a system, component, or process</i>	PI-1	Gate 5 - Technical content Gate 5 - Operation
	<i>Evaluation and analysis of a broadly defined technological problem related to a system, component, or process</i>	PI-2	Final Report
	<i>Design and document a creative solution to a broadly-defined technological problem</i>	PI-3	Final Report
3.3ORAL	<b>an ability to apply written, oral, and graphical communication in both technical and non-technical environments; and an ability to identify and use appropriate technical literature</b>		
	<i>Organization &amp; Theme</i>	PI-1	Gate 5 - Total Score
	<i>Language</i>	PI-2	Gate 5 - Oral Communication
	<i>Delivery</i>	PI-3	
	<i>Supporting Material</i>	PI-4	Gate 5 - Technical Content Gate 5 - Graphical Communication
	<i>Visual/Graphics</i>	PI-5	
3.3WRIT	<b>An ability to <i>apply</i> written, oral, and graphical communication in both technical and non-technical environments; and an ability to <i>identify</i> and <i>use</i> appropriate technical literature</b>		
	<i>Context of and Purpose of Writing</i>	PI-1	Final Report
	<i>Content Development</i>	PI-2	Final Report
	<i>Convention &amp; Mechanics</i>	PI-3	Final Report
	<i>Sources and Evidence</i>	PI-4	References & Literature in Final Report
	<i>Visuals/Graphics</i>	PI-5	Final Report
3.5	<b>An ability to <i>function</i> effectively as a member of a technical team</b>		
	<i>Contributes to Team Meetings</i>	PI-1	Self-evaluation
	<i>Individual Contributions Outside of Team Meetings</i>	PI-2	
	<i>Fosters Constructive Team Climate</i>	PI-3	

**Conclusions**

Project based courses are a very powerful learning tool in preparing students to post graduation jobs. It emphasizes on many aspects needed by employers such as critical thinking, problem solving, team work and many more. This paper shows that capstone courses can be used to apply and emphasize this type of projects where students can take the responsibility of designing and implementing a complete project from brainstorming, to initial design to final steps of fabricating the product. It also emphasizes on oral and written communication skills which are all high attributes for ABET accreditation.

## Acknowledgement

The authors of the paper would like to acknowledge Carmyne Fanning for his permission to post the photos for his project in this paper.

## References

- [1] Shehadi, M., “Students’ responses to flipping Applied Fluids from instructor centered to a student-centered using PBL paradigm,” 2019 ASEE Annual Conference, 2019, Tampa, FL.
- [2] R. Wlodkowski, “Enhancing adult motivation to learn a comprehensive guide for teaching all adults,” San Francisco, CA: *Jossey-Bass*, 2008.
- [3] J.R. Weber, “Problem-based Learning Helps Bridge the Gap between the Classroom and the Real World,” *Magna Publications*, 2014. (Accessed online: [www.facultyfocus.com/author/jason-r-weber/](http://www.facultyfocus.com/author/jason-r-weber/))
- [4] Fanning, C., “The safety squat bar attachment,” Purdue Polytechnic Kokomo, Capstone Project, 2021.